



Act;on

MUSE

CREATIVE
INSPIRATIONS
NAOS

NAOS
THE ORIGINAL
ACTION
DESIGN



MUSE

CREATIVE
INSPIRATIONS
NAOS

ARTE COME RICERCA, COME CAPACITÀ DI IMMAGINARE, COME ARTE DEL FARE. NAOS ACTION DESIGN NASCE COME PROGETTO DA UN'IDEA ORIGINALE SULL'ESTETICA DEL MOVIMENTO E DELL'EMOZIONE: SUPERFICI CHE SI APRONO COME SIPARI, COME ALI DI CRISTALLO, PIANI DI CERAMICA CHE SI ESTENDONO SIMULTANEAMENTE, SCINTILLANTI INGRANAGGI CHE RUOTANO. NON SONO PIÙ SOLO OGGETTI D'ARREDO MA SCULTURE DINAMICHE, ESTETICA DOMESTICA CONTEMPORANEA.

ART AS RESEARCH, ABILITY TO IMAGINE, THE ART OF CREATING. NAOS ACTION DESIGN WAS A PROJECT ORIGINALLY BORN FROM AN IDEA OF AESTHETICS OF MOVEMENT AND EMOTION: SURFACES OPEN LIKE CURTAINS, LIKE CRYSTAL WINGS, CERAMIC TOPS THAT EXTEND SIMULTANEOUSLY, SPARKLING ROTATING CLOGS & GEARS. THEY ARE NO LONGER JUST FURNITURE, BUT DYNAMIC SCULPTURES, CONTEMPORARY DOMESTIC AESTHETICS.

L'ART EN TANT QUE RECHERCHE, CAPACITÉ D'IMAGINATION, ART DE FAIRE. NAOS ACTION DESIGN EST NÉE D'UNE IDÉE ORIGINALE SUR L'ESTHÉTIQUE DU MOUVEMENT ET DE L'ÉMOTION: DES SURFACES QUI S'OUVRENT COMME DES RIDEAUX, COMME DES AILES DE CRISTAL, DES PLATEAUX EN CÉRAMIQUE QUI S'ÉTENDENT SIMULTANÉMENT, DES ENGRENAGES SCINTILLANTS QUI TOURNENT. CE NE SONT PLUS SEULEMENT DES OBJETS D'AMEUBLEMENT, MAIS DES SCULPTURES DYNAMIQUES, UNE ESTHÉTIQUE DOMESTIQUE CONTEMPORAINE.

KUNST WIE FORSCHUNG, WIE VORSTELLUNGSFÄHIGKEIT, WIE KUNST DES TUNS. NAOS ACTION DESIGN STARTET ALS PROJEKT EINER ORIGINELLEN IDEE ÜBER ÄSTHETIK VON BEWEGUNG UND EMOTION : OBERFLÄCHEN DIE SICH WIE EIN BÜHNENVORHANG ÖFFNEN, WIE FLÜGEL AUS KRISTALL, KERAMIKTISCHPLATTEN DIE SICH GLEICHZEITIG VERLÄNGERN, GLÄNZENDE RÄDERWERKE DIE KREISEN. NICHT EINFACH NUR EINRICHTUNGSGEGENSTÄNDE, SONDERN DYNAMISCHE SKULPTUREN – MODERNE ZEITGENÖSSISCHE EINRICHTUNGSÄSTHETIK.

MOTION

UNCONVENTIONAL

STYLE

EMOTIONS





LOOKING FOR MY MUSE

ANIMATED MUSES
TABLES IN MOTION
PAG 9

INGENIOUS MUSES
UNCONVENTIONAL
COFFEE TABLES
PAG 121

CHARMING MUSES
STYLISH CHAIRS
PAG 247

DREAMING MUSES
EMOTION VARIATIONS
PAG 259

ANIMATED MUSES

TABLES IN MOTION



FLOWING TABLES

COLLECTION



QUASAR - PAG 15



GALAX - PAG 21



LATOURE - PAG 27



ZEUS - PAG 33



COLISEUM - PAG 37



MINOSSE - PAG 41



SOMNIA - PAG 45



PAR PAR - PAG 49



ARCADIO - PAG 55



DOUBLE - PAG 59



DIAPASON - PAG 63



DELTA - PAG 65



BRUNELLESCHI - PAG 69



EFESTO - PAG 75



LASTRE - PAG 79



FLOCCON - PAG 85

FLOWING TABLES

COLLECTION



SANTIAGO - PAG 89



FEELING - PAG 91



HELP - PAG 95



PLIÈ ROUND - PAG 103



TURNING SQUARE - PAG 97



TURNING ROUND - PAG 97



PLIÈ SQUARE - PAG 103



SOMNIA ROUND - PAG 105



BIG PLIÈ - PAG 107



INGENTS - PAG 109



SOMNIA SQUARE - PAG 105



CONVIVIUM - PAG 113



EQUUS - PAG 117

QUASAR

*TRANSPARENT
MUSE*





QUASAR design D. D'Urbino P. Lomazzi coll. Casati

QUASAR VariActions



LEGS 08 EXTRALIGHT GLASS - MECHANISM 37 CHROME - TOPS STONE SAVOIA PERLA



LEGS 08 EXTRALIGHT GLASS - MECHANISM 37 CHROME - TOPS STATUARIO



LEGS 37 CHROME - MECHANISM 7016 ANTRACITE / 37 CHROME - TOPS 08 EXTRALIGHT GLASS

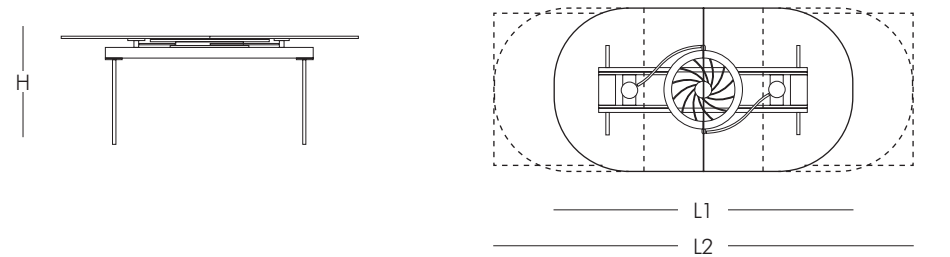

- L1 L2 P
- 200 → 280 x 110cm ov.
 - 200 → 280 x 100cm rect.
- H: 75 cm

TAVOLO DA PRANZO ESTENSIBILE CON PIANI E PROLUNGA IN CRISTALLO O CERAMICA. GAMBE IN ACCIAIO CROMATO O IN CRISTALLO STRATIFICATO DOTATO DI MECCANISMO SINCRONIZZATO PER L'APERTURA DEI PIANI LATERALI E L'INNALZAMENTO DELL' ALLUNGA CENTRALE. DISPONIBILE CON O SENZA MOTORE E TELECOMANDO.

EXTENSIBLE DINING TABLE WITH GLASS OR WITH CERAMIC TOPS. LEGS IN CHROMED STEEL OR IN STRATIFIED GLASS. EQUIPPED WITH A SYNCHRONIZED MECHANISM FOR LATERAL EXTENSIONS WIDENING AND CENTRAL EXTENSION LIFTING. AVAILABLE WITH OR WITHOUT REMOTE CONTROL.

TABLE DE REPAS ALLONGEABLE AVEC PLATEAUX ET RALLONGE EN VERRE OU CERAMIQUE. PIEDS EN ACIER CHROMÉ OU EN VERRE STRATIFIÉ. EQUIPÉE D'UN MÉCANISME SYNCHRONISÉ POUR OUVRIR LES PLATEAUX ET FAIRE MONTER LA RALLONGE CENTRALE. DISPONIBLE SANS OU AVEC MOTEUR ET TELECOMMANDE.

AUSZIEHBARER ESSTISCH MIT PLATTEN UND AUSZÜGEN AUS KRISTALLGLAS ODER AUS KERAMIK. BEINE AUS VERCHROMTEM STAHL ODER IM SCHICHTGLAS. AUSGESTATTET MIT EINER SYNCHRONMECHANIK FÜR DIE SEITLICHEN AUSZÜGEN UND ERHOEHUNG DER ZENTRALPLATTE. ERHÄLTICH MIT ODER OHNE FERNBEDIENUNG.

GALAX



GALAX design D. D'Urbino P. Lomazzi coll. Casati

GALAX VariActions



LEGS 34 SATIN NICKEL - MECHANISM 37 CHROME - TOPS 08 EXTRALIGHT GLASS



LEGS 44 ANTRACITE - MECHANISM 37 CHROME - TOPS 08 EXTRALIGHT GLASS / STONE SAVOIA ANTRACITE



LEGS 34 SATIN NICKEL - MECHANISM 37 CHROME - TOPS STONE SAVOIA PERLA

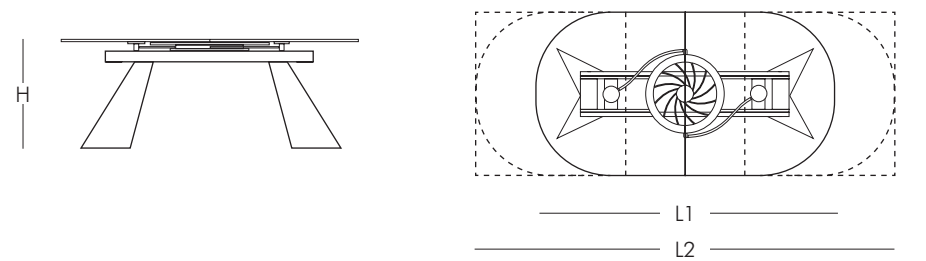

- | L1 | L2 | P |
|-------------|-------|----------|
| • 200 → 280 | x 110 | cm ov. |
| • 200 → 280 | x 100 | cm rect. |
| H: 75 cm | | |

TAVOLO DA PRANZO ESTENSIBILE CON PIANI E PROLUNGA IN CRISTALLO O CERAMICA. GAMBE IN ACCIAIO CROMATO O VERNICIATO DOTATO DI MECCANISMO SINCRONIZZATO PER L'APERTURA DEI PIANI LATERALI E L'INNALZAMENTO DELL' ALLUNGA CENTRALE. DISPONIBILE CON O SENZA MOTORE E TELECOMANDO.

EXTENSIBLE DINING TABLE WITH GLASS OR CERAMIC TOPS. LEGS IN CHROMED OR PAINTED STEEL. EQUIPPED WITH A SYNCHRONIZED MECHANISM FOR LATERAL EXTENSIONS WIDENING AND CENTRAL EXTENSION LIFTING. AVAILABLE WITH OR WITHOUT REMOTE CONTROL.

TABLE REPAS EXTENSIBLE AVEC PLATEAUX ET RALLONGE EN VERRE OU CERAMIQUE. PIEDS EN ACIER CHROMÉ OU LAQUÉ; EQUIPÉE D'UN MÉCANISME SYNCHRONISÉ POUR L'OUVERTURE DES PLATEAUX ET LE SOULEVEMENT DE LA RALLONGE CENTRALE. DISPONIBLE SOIT AVEC OU SANS MOTEUR ET TELECOMMANDE.

AUSZIEHBARER ESSTISCH MIT PLATTE UND AUSZÜGEN AUS KRISTALLGLAS ODER KERAMIK. BEINE AUS VERCHROMTEM ODER LACKIERTEM STAHL. AUSGESTATTET MIT EINER SYNCHRONISIERTEN MECHANISMUS ZUR ÖFFNUNG DER SEITLICHEN AUSZÜGEN UND ERHEBUNG DER ZENTRALPLATTE. ZFERNBEDIENUNG.

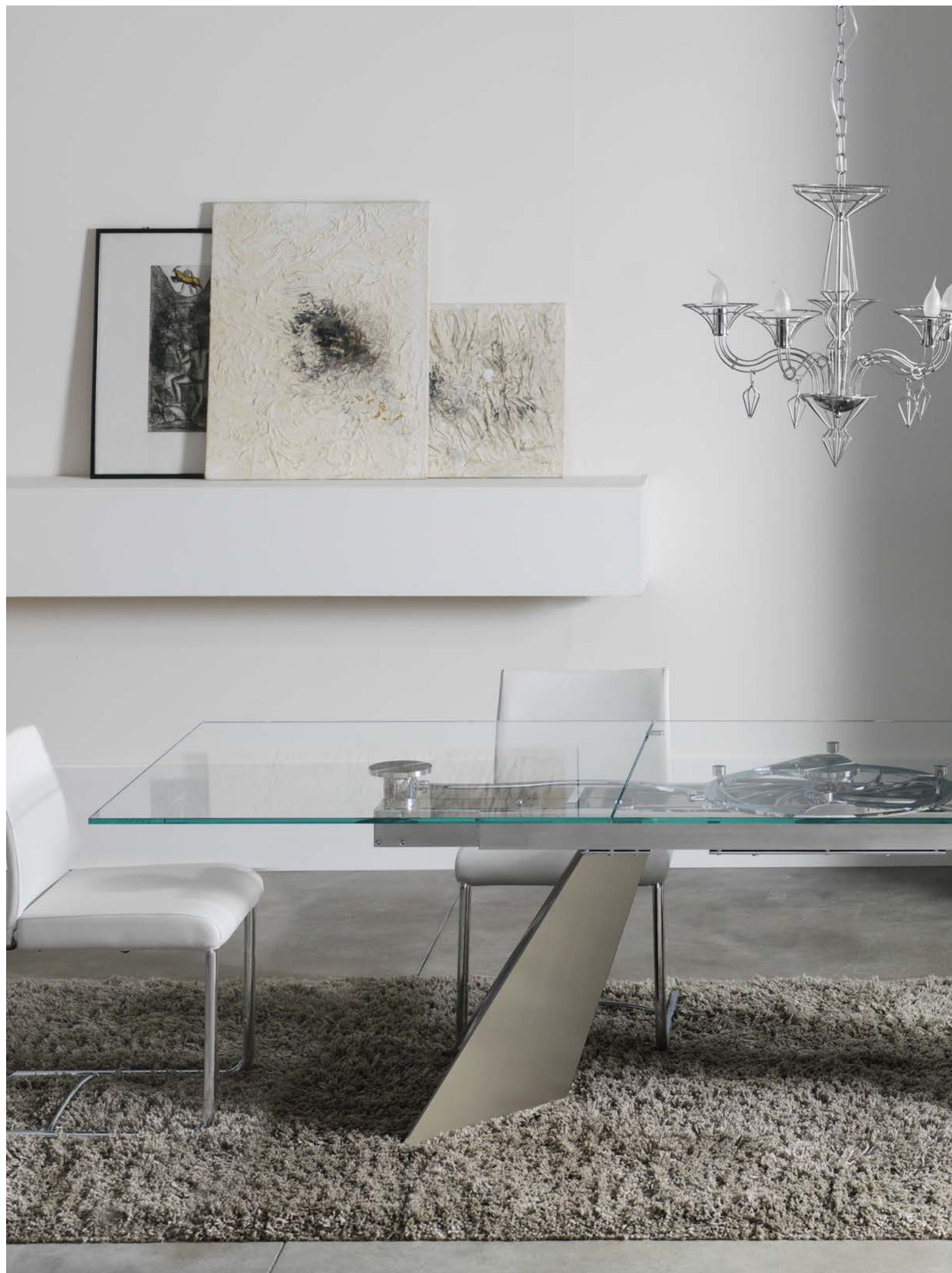

LATOUR

SPIRALING
MUSE





LATOURE design A. Casati

LATOURE VariActions



FRAME & MECHANISM 11 MATT BLACK - TOPS 08 EXTRALIGHT GLASS



FRAME & MECHANISM 31BR BRONZO CHAMPAGNE - TOPS CALACATTA



FRAME 670 COPPER - MECHANISM 11 MATT BLACK - TOPS BLACK DESIRE

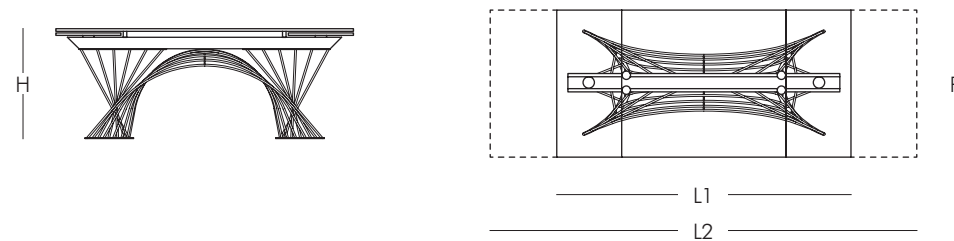

- | L1 | L2 | P |
|----------------------|----|---|
| • 180 → 260 x 100 cm | | |
| • 200 → 280 x 100 cm | | |
| • 220 → 300 x 100 cm | | |
| H: 75 cm | | |

TAVOLO DA PRANZO ESTENSIBILE, CON PIANO E PROLUNGHE IN CRISTALLO. BASE E BINARI IN METALLO CROMATO O VERNICIATO. DOTATO DI UN AGEVOLE MECCANISMO BREVETTATO, PER ESTRARRE LE PROLUNGHE LATERALI CHE CONSENTE DI AMPLIARE IL PIANO DI CM 80. DISPONIBILE ANCHE CON PIANI IN CERAMICA.

EXTENSIBLE DINING TABLE, WITH TOP AND EXTENSIONS OF GLASS. BASE AND TRACK OF CHROMED OR PAINTED METAL. A VERY EASY PATENTED MECHANISM TO PULL OUT THE LATERAL EXTENSIONS ALLOWS THE WIDENING OF THE TOP OF CM 80. AVAILABLE ALSO WITH CERAMICS TOPS.

TABLE REPAS EXTENSIBLE AVEC PLATEAU ET RALLONGES EN VERRE. BASE ET RAILS EN METAL CHROME' OU LAQUE'. EQUIPEE D'UN MECANISME BREVETE' TRÈS A'L'AISE QUI PERMET AUX RALLONGES DE S'ÉTENDRE ET DE PROLONGER LA SURFACE DE CM 80. DISPONIBILE AUSSI AVEC PLATEAUX EN CERAMIQUE.

AUSZIEHBARER ESSTISCH MIT PLATTE UND AUSZÜGEN AUS GLAS. BASIS UND GLEISE AUS METALL, VERCHROMT ODER LACKIERT. EINEN BEQUEMEN PATENTIERTEN MECHANISMUS FÜR DIE SEITENAUSZÜGE ERLAUBT ES DEN TISCH UM CM 80 ZU VERGRÖßERN. LIEFERBAR AUCH MIT KERAMIKPLATTEN.

ZEUS



ZEUS *design Y. Hatano*

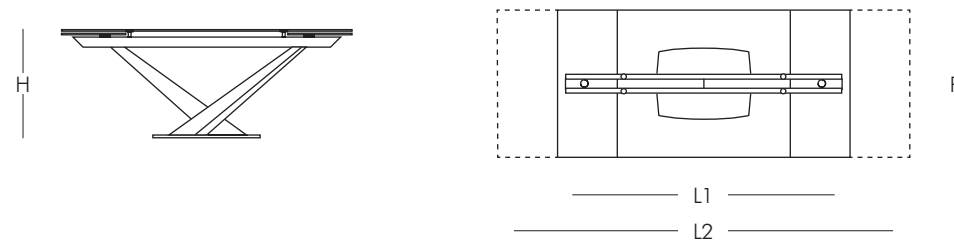

- | | L1 | L2 | P |
|---|-----------|-----|----|
| • | 180 → 260 | 100 | 75 |
| • | 200 → 280 | 100 | 75 |
- H: 75 cm

TAVOLO DA PRANZO ESTENSIBILE, CON PIANO E PROLUNGHE IN CRISTALLO. BASE E BINARIO IN METALLO VERNICIATO. DOTATO DI UN AGEVOLE MECCANISMO BREVETTATO, PER ESTRARRE LE PROLUNGHE LATERALI CHE CONSENTE DI AMPIARE IL PIANO DI CM 80. DISPONIBILE ANCHE CON PIANI IN CERAMICA.

EXTENSIBLE DINING TABLE, WITH TOP AND EXTENSIONS OF GLASS. BASE AND TRACK OF PAINTED METAL. A VERY EASY PATENTED MECHANISM TO PULL OUT THE LATERAL EXTENSIONS ALLOWS THE WIDENING OF THE TOP OF CM 80 (31.5 INCH). AVAILABLE ALSO WITH CERAMICS TOPS.

TABLE DE SALON EXTENSIBLE AVEC PATEAU ET ALLONGES EN VERRE. BASE ET RAILS EN METAL LAQUE'. ÉQUIPÉE D'UN MÉCANISME BREVETÉ TRÉS SIMPLE D'UTILISATION QUI PERMET AUX ALLONGES DE SE DÉPLOYER ET DE PROLONGER LA SURFACE DE 80 CM. DISPONIBLE AUSSI AVEC PATEUX EN CERAMIQUE.

AUSZIEHBARER ESSTISCH MIT PLATTE UND AUSZUEGEN AUS KRISTALLGLAS, GESTELL UND GLEISE AUS METALL, LACKIERT. EIN BEQUEMENR PATENTIERTER MECHANISMUS FÜR DIE SEITENAUSZUEGE ERLAUBT ES DEN TISCH UM CM 80 ZU VERGROESSERN. LIEFERBAR AUCH MIT KERAMIKPLATTEN.

ZEUS *VariActions*



BASE LEGS & MECHANISM 7044 SAND - TOPS STATUARIO



BASE LEGS & MECHANISM 2525 MANGANESE - TOPS STONE BLACK STONE



BASE LEGS & MECHANISM 11 MATT BLACK - TOPS BLACK DESIRE

COLISEUM



COLISEUM *design A. Casati*

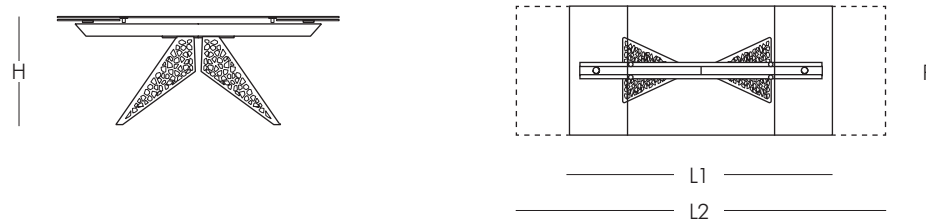

- | L1 | L2 | P |
|----------------------|----|---|
| • 180 → 260 x 100 cm | | |
| • 200 → 280 x 100 cm | | |
| • 220 → 300 x 100 cm | | |
| H: 75cm | | |

TAVOLO DA PRANZO ESTENSIBILE, CON PIANO E PROLUNGHE IN CRISTALLO. BASE E BINARIO IN METALLO CROMATO O VERNICIATO. DOTATO DI UN AGEVOLE MECCANISMO BREVETTATO, PER ESTRARRE LE PROLUNGHE LATERALI CHE CONSENTE DI AMPLIARE IL PIANO DI CM 80. DISPONIBILE ANCHE CON PIANI IN CERAMICA.

EXTENSIBLE DINING TABLE, WITH TOP AND EXTENSIONS OF GLASS. BASE AND TRACK OF CHROMED OR PAINTED METAL. A VERY EASY PATENTED MECHANISM TO PULL OUT THE LATERAL EXTENSIONS ALLOWS THE WIDENING OF THE TOP OF CM 80 (31.5 INCH). AVAILABLE ALSO WITH CERAMICS TOPS.

TABLE DE SALON EXTENSIBLE AVEC PATEAU ET ALLONGES EN VERRE. BASE ET RAILS EN METAL LAQUE'. ÉQUIPÉE D'UN MÉCANISME BREVETÉ TRÈS SIMPLE D'UTILISATION QUI PERMET AUX ALLONGES DE SE DÉPLOYER ET DE PROLONGER LA SURFACE DE 80 CM. DISPONIBLE AUSSI AVEC PATEUX EN CERAMIQUE.

AUSZIEHBARER ESSTISCH MIT PLATTE UND AUSZUEGEN AUS KRISTALLGLAS, GESTELL UND GLEISE AUS METALL, LACKIERT. EIN BEQUEMENR PATENTIERTER MECHANISMUS FÜR DIE SEITENAUSZUEGE ERLAUBT ES DEN TISCH UM CM 80 ZU VERGROESSERN. LIEFERBAR AUCH MIT KERAMIKPLATTEN.

COLISEUM *VariActions*



LEGS 570 SMOKE - MECHANISM 11 MATT BLACK - TOPS SAHARA NOIR



LEGS & MECHANISM 11 MATT BLACK - TOPS ARABESCATO



LEGS 570 SMOKE - MECHANISM 11 MATT BLACK - TOPS FUSION WHITE

MINOSSE



MINOSSE *design Y. Hatano*

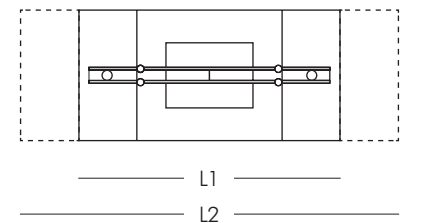
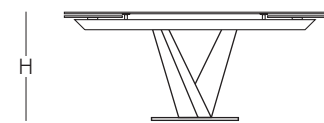

- | L1 | L2 | P |
|----------------------|----|---|
| • 160 → 240 x 100 cm | | |
| • 180 → 260 x 100 cm | | |
| • 200 → 280 x 100 cm | | |
- H: 75 cm

TAVOLO DA PRANZO ESTENSIBILE, CON PIANO E PROLUNGHE IN CRISTALLO. BASE E BINARI IN METALLO CROMATO O VERNICIATO. DOTATO DI UN AGEVOLE MECCANISMO BREVETTATO, PER ESTRARRE LE PROLUNGHE LATERALI CHE CONSENTE DI AMPLIARE IL PIANO DI CM 80. DISPONIBILE ANCHE CON PIANI IN CERAMICA.

EXTENSIBLE DINING TABLE, WITH TOP AND EXTENSIONS OF GLASS. BASE AND TRACK OF CHROMED OR PAINTED METAL. A VERY EASY PATENTED MECHANISM TO PULL OUT THE LATERAL EXTENSIONS ALLOWS THE WIDENING OF THE TOP OF CM 80. AVAILABLE ALSO WITH CERAMICS TOPS.

TABLE REPAS EXTENSIBLE AVEC PLATEAU ET RALLONGES EN VERRE. BASE ET RAILS EN METAL CHROME' OU LAQUÉ. EQUIPEE D'UN MÉCANISME BREVETE' TRÈS A'L'AISE QUI PERMET AUX RALLONGES DE S'ÉTENDRE ET DE PROLONGER LA SURFACE DE CM 80. DISPONIBILE AUSSI AVEC PLATEAUX EN CERAMIQUE.

AUSZIEHBARER ESSTISCH MIT PLATTE UND AUSZÜGEN AUS KRISTALLGLAS. BASIS UND GLEISE AUS METALL, VERCHROMT ODER LACKIERT. EINEN BEQUEMEN PATENTIERTEN MECHANISMUS FÜR DIE SEITENAUSZÜGE ERLAUBT ES DEN TISCH UM CM 80 ZU VERGRÖßERN. LIEFERBAR AUCH MIT KERAMIKPLATTEN.

MINOSSE *VariActions*



BASE SUPPORTS & MECHANISM 44 ANTRACITE - TOPS 08 EXTRALIGHT GLASS



BASE & SUPPORTS 37 CHROME - MECHANISM 48 SHINY BRUSHED ALUM - TOPS STONE SAVOIA ANTRACITE



BASE SUPPORTS & MECHANISM 10 MATT WHITE - TOPS STONE SAVOIA PERLA

SOMNIA



SOMNIA *design A. Casati*

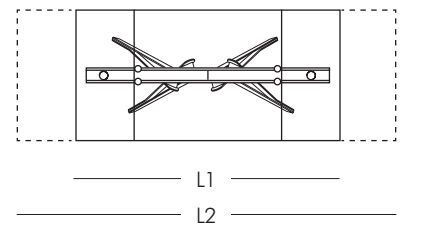
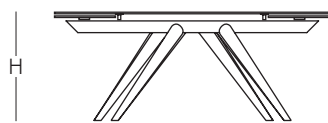

- | L1 | L2 | P |
|----------------------|----|---|
| • 180 → 260 x 100 cm | | |
| • 200 → 280 x 100 cm | | |
| • 220 → 300 x 100 cm | | |
| H: 75cm | | |

TAVOLO DA PRANZO ESTENSIBILE, CON PIANO E PROLUNGHE IN CRISTALLO. BASE E BINARIO IN METALLO VERNICIATO. DOTATO DI UN AGEVOLE MECCANISMO BREVETTATO, PER ESTRARRE LE PROLUNGHE LATERALI CHE CONSENTE DI AMPLIARE IL PIANO DI CM 80. DISPONIBILE ANCHE CON PIANI IN CERAMICA.

EXTENSIBLE DINING TABLE, WITH TOP AND EXTENSIONS OF GLASS. BASE AND TRACK OF PAINTED METAL. A VERY EASY PATENTED MECHANISM TO PULL OUT THE LATERAL EXTENSIONS ALLOWS THE WIDENING OF THE TOP OF CM 80 (31.5 INCH). AVAILABLE ALSO WITH CERAMICS TOPS.

TABLE DE SALON EXTENSIBLE AVEC PLATEAU ET ALLONGES EN VERRE. BASE ET RAILS EN METAL LAQUE'. ÉQUIPÉE D'UN MÉCANISME BREVETÉ TRÉS SIMPLE D'UTILISATION QUI PERMET AUX ALLONGES DE SE DÉPLOYER ET DE PROLONGER LA SURFACE DE 80 CM. DISPONIBLE AUSSI AVEC PLATEUX EN CERAMIQUE.

AUSZIEHBARER ESSTISCH MIT PLATTE UND AUSZUEGEN AUS KRISTALLGLAS, GESTELL UND GLEISE AUS METALL, LACKIERT. EIN BEQUEMENR PATENTIERTER MECHANISMUS FÜR DIE SEITENAUSZUEGE ERLAUBT ES DEN TISCH UM CM 80 ZU VERGROESSERN. LIEFERBAR AUCH MIT KERAMIKPLATTEN.

SOMNIA *VariActions*



LEGS & MECHANISM 7044 SAND - TOPS STONE FOKOS SALE



LEGS & MECHANISM 5270 DARK BROWN - TOPS STONE FOKOS TERRA



LEGS & MECHANISM 24 EMBOSSED ALUMINIUM - TOPS CALACATTA BLACK

PAR PAR

FLYING INSPIRATION





PAR PAR *design D. D'Urbino*

PAR PAR *VariActions*



FRAME & MECHANISM 31BR BRONZO CHAMPAGNE - TOPS CALACATTA



FRAME & MECHANISM 31BR BRONZO CHAMPAGNE - TOPS STONE SAVOIA ANTRACITE



FRAME & MECHANISM 7016 MATT ANTRACITE - TOPS STONE FOKOS SALE

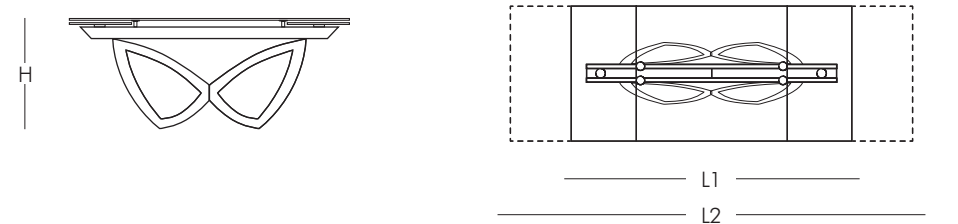

- | L1 | L2 | P |
|-------------|-------|----|
| • 180 → 260 | x 100 | cm |
| • 200 → 280 | x 100 | cm |
| • 220 → 300 | x 100 | cm |
| H: 75 cm | | |

TAVOLO DA PRANZO ESTENSIBILE, CON PIANO E PROLUNGHE IN CRISTALLO. BASE E BINARI IN METALLO CROMATO O VERNICIATO. DOTATO DI UN AGEVOLE MECCANISMO BREVETTATO, PER ESTRARRE LE PROLUNGHE LATERALI CHE CONSENTE DI AMPLIARE IL PIANO DI CM 80. DISPONIBILE ANCHE CON PIANI IN CERAMICA.

EXTENSIBLE DINING TABLE, WITH TOP AND EXTENSIONS OF GLASS. BASE AND TRACK OF CHROMED OR PAINTED METAL. A VERY EASY PATENTED MECHANISM TO PULL OUT THE LATERAL EXTENSIONS ALLOWS THE WIDENING OF THE TOP OF CM 80. AVAILABLE ALSO WITH CERAMICS TOPS.

TABLE REPAS EXTENSIBLE AVEC PLATEAU ET RALLONGES EN VERRE. BASE ET RAILS EN METAL CHROME' OU LAQUÉ. EQUIPEE D'UN MÉCANISME BREVETE' TRÈS A'L'AISE QUI PERMET AUX RALLONGES DE S'ÉTENDRE ET DE PROLONGER LA SURFACE DE CM 80. DISPONIBILE AUSSI AVEC PLATEAUX EN CERAMIQUE.

AUSZIEHBARER ESSTISCH MIT PLATTE UND AUSZÜGEN AUS KRISTALLGLAS. BASIS UND GLEISE AUS METALL, VERCHROMT ODER LACKIERT. EINEN BEQUEMEN PATENTIERTEN MECHANISMUS FÜR DIE SEITENAUSZÜGE ERLAUBT ES DEN TISCH UM CM 80 ZU VERGRÖßERN. LIEFERBAR AUCH MIT KERAMIKPLATTEN.

ARCADIO



ARCADIO *design D. D'Urbino P. Lomazzi*

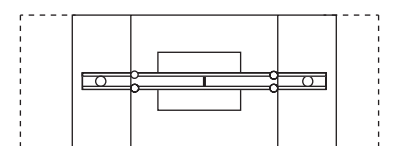
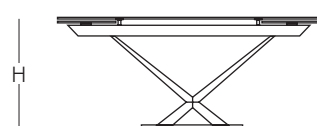

- | L1 | L2 | P |
|----------------------|----|---|
| • 180 → 260 x 100 cm | | |
| • 200 → 280 x 100 cm | | |
| • 220 → 300 x 100 cm | | |
- H: 75 cm

TAVOLO DA PRANZO ESTENSIBILE CON PIANO E PROLUNGHE IN CRISTALLO. GAMBE IN ACCIAIO VERNICIATO. DOTATO DI UN AGEVOLE MECCANISMO BREVETTATO IN ALLUMINIO VERNICIATO O SPAZZOLATO PER ESTRARRE LE PROLUNGHE LATERALI CHE CONSENTE DI AMPLIARE IL PIANO DI CM 80. DISPONIBILE ANCHE CON PIANI IN CERAMICA.

EXTENSIBLE DINING TABLE WITH GLASS TOP AND EXTENSIONS. LEGS IN PAINTED STEEL. A VERY EASY MECHANISM IN PAINTED ALUMINIUM TO PULL OUT THE EXTENSIONS ALLOWS THE WIDENING OF THE TOP OF CM 80. AVAILABLE ALSO WITH CERAMICS TOPS.

TABLE DE REPAS EXTENSIBLE AVEC PLATEAU ET RALLONGES EN VERRE. PIEDS EN ACIER CHROME OU LAQUÉ. UN MÉCANISME EN ALUMINIUM LAQUÉ TRÈS FACILE PERMET AUX RALLONGES DE S'ÉTENDRE ET DE PROLONGER LA SURFACE DE CM 80. DISPONIBILE AUSSI AVEC PLATEAUX EN CERAMIQUE.

AUSZIEHBARER ESSTISCH MIT PLATTEN UND AUSZÜGEN AUS KRISTALLGLAS. BEINE AUS GEBÜRSTETEM ODER LACKIERTEM STAHL. EIN KOMFORTABLER MECHANISMUS AUS LACKIERTEM ALUMINIUM ERLAUBT ES DEN TISCH UM CM 80 ZU VERGRÖßERN. LIEFERBAR AUCH MIT KERAMIKPLATTEN.

ARCADIO *VariActions*



BASE SUPPORTS & MECHANISM 7044 SAND - TOPS STONE SAVOIA PERLA



BASE 37 CHROME - SUPPORTS 110 SHINY WHITE - MECHANISM 10 MATT WHITE - TOPS CALACATTA



BASE 37 CHROME - SUPPORTS 300 SHINY BLACK - MECHANISM 48 SHINY BRUSHED ALUM - TOPS STONE SAVOIA ANTRACITE

DOUBLE



DOUBLE *design A. Lucatello*

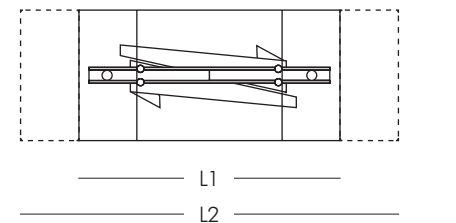
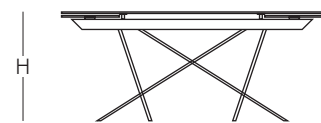

- | L1 | L2 | P |
|----------------------|----|---|
| • 180 → 260 x 100 cm | | |
| • 200 → 280 x 100 cm | | |
| • 220 → 300 x 100 cm | | |
| H: 75 cm | | |

TAVOLO DA PRANZO ESTENSIBILE, CON PIANO E PROLUNGHE IN CRISTALLO. GAMBE E BINARI IN METALLO VERNICIATO. DOTATO DI UN AGEVOLE MECCANISMO BREVETTATO, PER ESTRARRE LE PROLUNGHE LATERALI CHE CONSENTE DI AMPLIARE IL PIANO DI CM 80. DISPONIBILE ANCHE CON PIANI IN CERAMICA.

EXTENSIBLE DINING TABLE WITH TOPS AND EXTENSIONS IN GLASS. LEGS AND TRACK IN PAINTED METAL. EQUIPPED WITH AN EASY PATENTED MECHANISM TO PULL OUT THE LATERAL EXTENSIONS ALLOWING THE WIDENING OF THE TOP OF CM 80. AVAILABLE ALSO WITH CERAMIC TOPS.

TABLE REPAS EXTENSIBLE AVEC PLATEAU ET RALLONGES EN VERRE. PIEDS ET RAIL EN METAL LAQUÉ; EQUIPÉE D'UN MÉCANISME BREVETÉ TRÈS FACILE À L'USAGE, POUR L'EXTRACTION DES RALLONGES QUI PERMET D'AGRANDIR LA SURFACE DE 80 CM. DISPONIBLE AUSSI AVEC PLATEAUX CERAMIQUE.

AUSZIEHBARER ESSTISCH MIT PLATTE UND AUSZÜGEN AUS KRISTALLGLAS. BEINE UND GLEISE AUS LACKIERTEM METALL. AUSGESTATTET MIT EINER BEQUEMEN PATENTIERTEN MECHANISMUS ZUR ÖFFNUNG DER SEITLICHEN AUSZÜGEN, WELCHE DIE VERLÄNGERUNG DER PLATTE MIT 80 CM ERLAUBT. AUCH VERFÜGBAR MIT KERAMIKPLATTEN.

DOUBLE *VariActions*



FRAME & MECHANISM 11 MATT BLACK - TOPS 00 NATURAL GLASS



FRAME & MECHANISM 10 MATT WHITE - TOPS CALACATTA



FRAME & MECHANISM 31 BR BRONZO CHAMPAGNE - TOPS STONE BLACK STONE

DIAPASON

design A. Casati

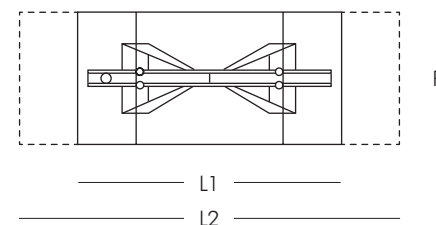
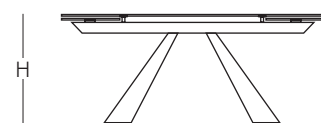

- | L1 | L2 | P |
|-------------|-------|----|
| • 180 → 260 | x 100 | cm |
| • 200 → 280 | x 100 | cm |
| • 220 → 300 | x 100 | cm |
- H: 75 cm

TAVOLO DA PRANZO ESTENSIBILE, CON PIANO E PROLUNGHE IN CRISTALLO. BASE E BINARI IN METALLO VERNICIATO. DOTATO DI UN AGEVOLE MECCANISMO BREVETTATO, PER ESTRARRE LE PROLUNGHE LATERALI CHE CONSENTE DI AMPIARE IL PIANO DI CM 80. DISPONIBILE ANCHE CON PIANI IN CERAMICA.

EXTENSIBLE DINING TABLE, WITH TOP AND EXTENSIONS OF GLASS. BASE AND TRACK OF PAINTED METAL. A VERY EASY PATENTED MECHANISM TO PULL OUT THE LATERAL EXTENSIONS ALLOWS THE WIDENING OF THE TOP OF CM 80. AVAILABLE ALSO WITH CERAMICS TOPS.

TABLE REPAS EXTENSIBLE AVEC PATEAU ET RALLONGES EN VERRE. BASE ET RAILS EN METAL LAQUE. EQUIPEE D'UN MECANISME BREVETE' TRÈS A'L'AISE QUI PERMET AUX RALLONGES DE S'ÉTENDRE ET DE PROLONGER LA SURFACE DE CM 80. DISPONIBILE AUSSI AVEC PATEAUX EN CERAMIQUE.

AUSZIEHBARER ESSTISCH MIT PLATTE UND AUSZÜGEN AUS KRISTALLGLAS. BASIS UND GLEISE AUS METALL LACKIERT. EINEN BEQUEMEN PATENTIERTEN MECHANISMUS FÜR DIE SEITENAUSZÜGE ERLAUBT ES DEN TISCH UM CM 80 ZU VERGRÖßERN. LIEFERBAR AUCH MIT KERAMIKPLATTEN.



DELTA



DELTA *design Naos*

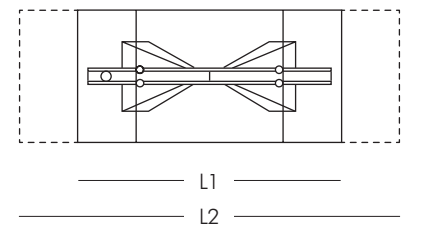
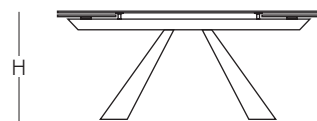

- | L1 | L2 | P |
|----------------------|----|---|
| • 180 → 260 x 100 cm | | |
| • 200 → 280 x 100 cm | | |
| • 220 → 300 x 100 cm | | |
| H: 75 cm | | |

TAVOLO DA PRANZO ESTENSIBILE, CON PIANO E PROLUNGHE IN CRISTALLO. BASE E BINARI IN METALLO GALVANIZZATO O VERNICIATO. DOTATO DI UN AGEVOLE MECCANISMO BREVETTATO, PER ESTRARRE LE PROLUNGHE LATERALI CHE CONSENTE DI AMPLIARE IL PIANO DI CM 80. DISPONIBILE ANCHE CON PIANI IN CERAMICA.

EXTENSIBLE DINING TABLE, WITH TOP AND EXTENSIONS OF GLASS. BASE AND TRACK OF GALVANIZED OR PAINTED METAL. A VERY EASY PATENTED MECHANISM TO PULL OUT THE LATERAL EXTENSIONS ALLOWS THE WIDENING OF THE TOP OF CM 80. AVAILABLE ALSO WITH CERAMICS TOPS.

TABLE REPAS EXTENSIBLE AVEC PLATEAU ET RALLONGES EN VERRE. BASE ET RAILS EM METAL GALVANISÉ OU LAQUÉ. EQUIPEE D'UN MÉCANISME BREVETE' TRÈS A'L'AISE QUI PERMET AUX RALLONGES DE S'ÉTENDRE ET DE PROLONGER LA SURFACE DE CM 80. DISPONIBILE AUSSI AVEC PLATEAUX EN CERAMIQUE.

AUSZIEHBARER ESSTISCH MIT PLATTE UND AUSZÜGEN AUS KRISTALLGLAS. BASIS UND GLEISE AUS METALL, GALVANISIERTES ODER LACKIERT. EINEN BEQUEMEN PATENTIERTEN MECHANISMUS FÜR DIE SEITENAUSZÜGE ERLAUBT ES DEN TISCH UM CM 80 ZU VERGRÖßERN. LIEFERBAR AUCH MIT KERAMIKPLATTEN.

DELTA *VariActions*



LEGS 670 COPPER - MECHANISM 11 MATT BLACK - TOPS 08 EXTRALIGHT GLASS



LEGS 670 COPPER - MECHANISM 11 MATT BLACK - TOPS BLACK DESIRE



LEGS & MECHANISM 2525 MANGANESE - TOPS STONE FOKOS SALE

BRUNELLESCHI

design A. Casati





BRUNELLESCHI *design A. Casati*

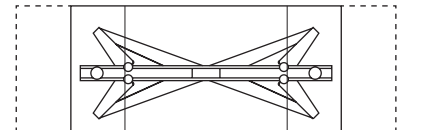
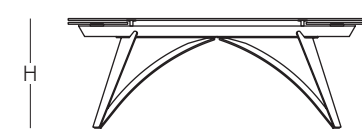

L1
L2

- | L1 | L2 | P |
|----------------------|----|---|
| • 180 → 260 x 100 cm | | |
| • 200 → 280 x 100 cm | | |
| • 220 → 300 x 100 cm | | |
| H: 75cm | | |

TAVOLO DA PRANZO ESTENSIBILE, CON PIANO E PROLUNGHE IN CRISTALLO. BASE E BINARIO IN METALLO VERNICIATO. DOTATO DI UN AGEVOLE MECCANISMO BREVETTATO, PER ESTRARRE LE PROLUNGHE LATERALI CHE CONSENTE DI AMPIARE IL PIANO DI CM 80. DISPONIBILE ANCHE CON PIANI IN CERAMICA.

EXTENSIBLE DINING TABLE, WITH TOP AND EXTENSIONS IN GLASS. BASE AND TRACK IN PAINTED METAL. A VERY EASY PATENTED MECHANISM TO PULL OUT THE LATERAL EXTENSIONS ALLOWS THE WIDENING OF THE TOP OF CM 80 (31.5 INCH). AVAILABLE ALSO WITH CERAMICS TOPS.

TABLE DE SALON EXTENSIBLE AVEC PATEAU ET ALLONGES EN VERRE. BASE ET RAILS EN METAL LAQUE'. ÉQUIPÉE D'UN MÉCANISME BREVETÉ TRÉS SIMPLE D'UTILISATION QUI PERMET AUX ALLONGES DE SE DÉPLOYER ET DE PROLONGER LA SURFACE DE 80 CM. DISPONIBLE AUSSI AVEC PATEUX EN CERAMIQUE.

AUSZIEHBARER ESSTISCH MIT PLATTE UND AUSZUEGEN AUS KRISTALLGLAS, GESTELL UND GLEISE AUS METALL, LACKIERT. EIN BEQUEMENR PATENTIERTER MECHANISMUS FÜR DIE SEITENAUSZUEGE ERLAUBT ES DEN TISCH UM CM 80 ZU VERGROESSERN. LIEFERBAR AUCH MIT KERAMIKPLATTEN.

BRUNELLESCHI *VariActions*



FRAME & MECHANISM 54 RUSTY BROWN - TOPS 00 NATURAL GLASS



FRAME & MECHANISM 507 BEIGE YAZD - TOPS FUSION WHITE



FRAME & MECHANISM 44 ANTRACITE - TOPS SAHARA NOIR

EFESTO



EFESTO *design A. Casati*

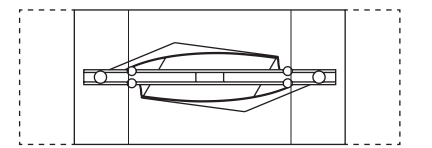
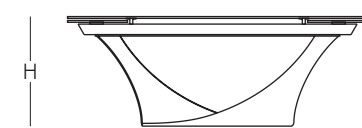

L1
L2

- | L1 | L2 | P |
|-------------|-------|----|
| • 180 → 260 | x 100 | cm |
| • 200 → 280 | x 100 | cm |
| • 220 → 300 | x 100 | cm |
- H: 75cm

TAVOLO DA PRANZO ESTENSIBILE, CON PIANO E PROLUNGHE IN CRISTALLO. BASE E BINARIO IN METALLO VERNICIATO. DOTATO DI UN AGEVOLE MECCANISMO BREVETTATO, PER ESTRARRE LE PROLUNGHE LATERALI CHE CONSENTE DI AMPLIARE IL PIANO DI CM 80. DISPONIBILE ANCHE CON PIANI IN CERAMICA.

EXTENSIBLE DINING TABLE, WITH TOP AND EXTENSIONS IN GLASS. BASE AND TRACK IN PAINTED METAL. A VERY EASY PATENTED MECHANISM TO PULL OUT THE LATERAL EXTENSIONS ALLOWS THE WIDENING OF THE TOP OF CM 80 (31.5 INCH). AVAILABLE ALSO WITH CERAMICS TOPS.

TABLE DE SALON EXTENSIBLE AVEC PATEAU ET ALLONGES EN VERRE. BASE ET RAILS EN METAL LAQUE'. ÉQUIPÉE D'UN MÉCANISME BREVETÉ TRÈS SIMPLE D'UTILISATION QUI PERMET AUX ALLONGES DE SE DÉPLOYER ET DE PROLONGER LA SURFACE DE 80 CM. DISPONIBLE AUSSI AVEC PATEUX EN CERAMIQUE.

AUSZIEHBARER ESSTISCH MIT PLATTE UND AUSZUEGEN AUS KRISTALLGLAS, GESTELL UND GLEISE AUS METALL, LACKIERT. EIN BEQUEMENR PATENTIERTER MECHANISMUS FÜR DIE SEITENAUSZUEGE ERLAUBT ES DEN TISCH UM CM 80 ZU VERGROESSERN. LIEFERBAR AUCH MIT KERAMIKPLATTEN.

EFESTO *VariActions*



FRAME & MECHANISM 11 MATT BLACK - TOPS 00 NATURAL GLASS



FRAME & MECHANISM 44 ANTRACITE - TOPS STONE SAVOIA PERLA



FRAME & MECHANISM 7016 MANGANESE - TOPS CALACATTA BLACK

LASTRE

design A. Casati





LASTRE *design A. Casati*

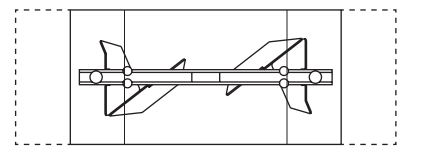
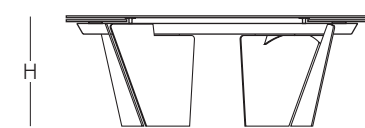

L1
L2

- | L1 | L2 | P |
|----------------------|----|---|
| • 180 → 260 x 100 cm | | |
| • 200 → 280 x 100 cm | | |
| • 220 → 300 x 100 cm | | |
- H: 75cm

TAVOLO DA PRANZO ESTENSIBILE, CON PIANO E PROLUNGHE IN CRISTALLO. BASE E BINARIO IN METALLO VERNICIATO. DOTATO DI UN AGEVOLE MECCANISMO BREVETTATO, PER ESTRARRE LE PROLUNGHE LATERALI CHE CONSENTE DI AMPLIARE IL PIANO DI CM 80. DISPONIBILE ANCHE CON PIANI IN CERAMICA.

EXTENSIBLE DINING TABLE, WITH TOP AND EXTENSIONS IN GLASS. BASE AND TRACK IN PAINTED METAL. A VERY EASY PATENTED MECHANISM TO PULL OUT THE LATERAL EXTENSIONS ALLOWS THE WIDENING OF THE TOP OF CM 80 (31.5 INCH). AVAILABLE ALSO WITH CERAMICS TOPS.

TABLE DE SALON EXTENSIBLE AVEC PLATEAU ET ALLONGES EN VERRE. BASE ET RAILS EN METAL LAQUE'. ÉQUIPÉE D'UN MÉCANISME BREVETÉ TRÈS SIMPLE D'UTILISATION QUI PERMET AUX ALLONGES DE SE DÉPLOYER ET DE PROLONGER LA SURFACE DE 80 CM. DISPONIBLE AUSSI AVEC PLATEUX EN CERAMIQUE.

AUSZIEHBARER ESSTISCH MIT PLATTE UND AUSZUEGEN AUS KRISTALLGLAS, GESTELL UND GLEISE AUS METALL, LACKIERT. EIN BEQUEMENR PATENTIERTER MECHANISMUS FÜR DIE SEITENAUSZUEGE ERLAUBT ES DEN TISCH UM CM 80 ZU VERGROESSERN. LIEFERBAR AUCH MIT KERAMIKPLATTEN.

LASTRE *VariActions*



FRAME & MECHANISM 7024 GRAPHITE - TOPS 00 NATURAL GLASS



FRAME & MECHANISM 54 RUSTY BROWN - TOPS CAPRAIA



FRAME & MECHANISM 51 SILVER / 11 MATT BLACK - TOPS SAHARA NOIR

FLOCON



FLOCON *design A. Casati*

FLOCON *VariActions*



FRAME & MECHANISM 11 MATT BLACK - TOPS CALACATTA / 00 NATURAL GLASS



FRAME & MECHANISM 7016 MATT ANTRACITE - TOPS BLACK DESIRE / 00 NATURAL GLASS



FRAME 7016 MATT ANTRACITE - MECHANISM 37 CHROME - TOPS STONE SAVOIA PERLA / 00 NATURAL GLASS

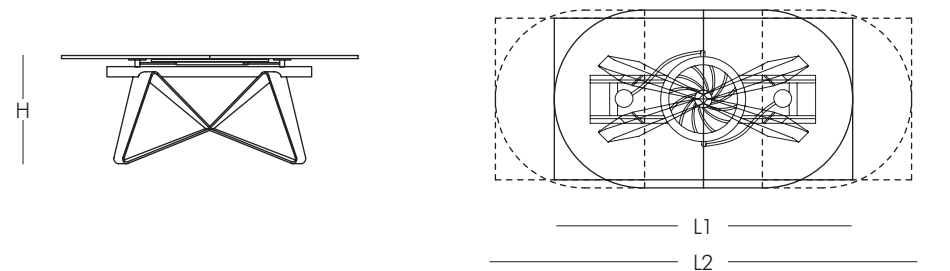

- L1 L2 P
- 200 → 280 x 110 cm ov.
 - 200 → 280 x 100 cm rect.
- H: 75 cm

TAVOLO DA PRANZO ESTENSIBILE CON PIANI E PROLUNGA IN CRISTALLO O CERAMICA. GAMBE IN ACCIAIO VERNICIATO. DOTATO DI MECCANISMO SINCRONIZZATO PER L'APERTURA DEI PIANI LATERALI E L'INNALZAMENTO DELL'ALLUNGA CENTRALE. DISPONIBILE CON O SENZA MOTORE E TELECOMANDO.

EXTENSIBLE DINING TABLE WITH GLASS OR WITH CERAMIC TOPS. LEGS IN PAINTED STEEL. EQUIPPED WITH A SYNCHRONIZED MECHANISM FOR LATERAL EXTENSIONS WIDENING AND CENTRAL EXTENSION LIFTING. AVAILABLE WITH OR WITHOUT REMOTE CONTROL.

TABLE DE REPAS ALLONGEABLE AVEC PLATEAUX ET RALLONGE EN VERRE OU CERAMIQUE. PIEDS EN ACIER LAQUE'. EQUIPEE D'UN MECANISME SYNCRONISE POUR OUVRIR LES PLATEAUX LATERAUX ET FAIRE MONTER LA RALLONGE CENTRALE. DISPONIBLE SANS OU AVEC MOTEUR ET TELECOMMANDE.

AUSZIEHBARER ESSTISCH MIT PLATTEN UND AUSZÜGEN AUS GLAS ODER AUS KERAMIK. BEINE AUS STAHL. AUSGESTATTET MIT EINER SYNCHRONMECHANIK FÜR DIE SEITLICHEN AUSZÜGEN UND ERHOEHUNG DER ZENTRALPLATTE. ERHÄLTICH MIT ODER OHNE FERNBEDIENUG.

SANTIAGO

design Naos

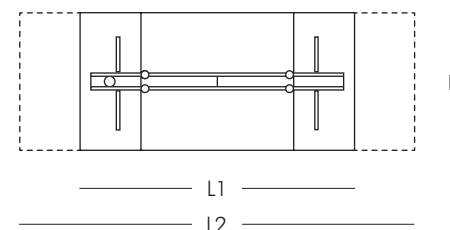
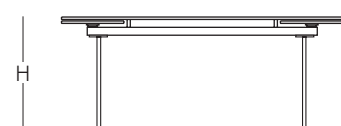

- | L1 | L2 | P |
|----------------------|----|---|
| • 180 → 260 x 100 cm | | |
| • 200 → 280 x 100 cm | | |
| • 220 → 300 x 100 cm | | |
- H: 75 cm

TAVOLO DA PRANZO ESTENSIBILE CON PIANO, PROLUNGHE E GAMBE IN CRISTALLO. DOTATO DI UN AGEVOLE MECCANISMO BREVETTATO, IN ALLUMINIO VERNICIATO O SPAZZOLATO, PER ESTRARRE LE PROLUNGHE LATERALI CHE CONSENTE DI AMPLIARE IL PIANO DI CM 80. DISPONIBILE ANCHE CON PIANI IN CERAMICA.

EXTENSIBLE DINING TABLE WITH GLASS TOP, EXTENSIONS AND LEGS. A VERY EASY MECHANISM IN PAINTED ALUMINIUM TO PULL OUT THE EXTENSIONS ALLOWS THE WIDENING OF THE TOP OF CM 80. AVAILABLE ALSO WITH CERAMICS TOPS.

TABLE DE REPAS EXTENSIBLE AVEC PLATEAU, RALLONGES ET EN PIEDS VERRE. UN MÉCANISME EN ALUMINIUM LAQUÉ TRÈS FACILE PERMET AUX RALLONGES DE S'ÉTENDRE ET DE PROLONGER LA SURFACE DE CM 80. DISPONIBILE AUSSI AVEC PLATEAUX EN CERAMIQUE.

AUSZIEHBARER ESSTISCH MIT PLATTEN, BEINE UND AUSZÜGEN AUS KRISTALLGLAS. EIN KOMFORTABLER MECHANISMUS AUS LACKIERTEM ALUMINIUM ERLAUBT ES DEN TISCH UM CM 80 ZU VERGRÖßERN. LIEFERBAR AUCH MIT KERAMIKPLATTEN.



FEELING



FEELING *design Y. Hatano*

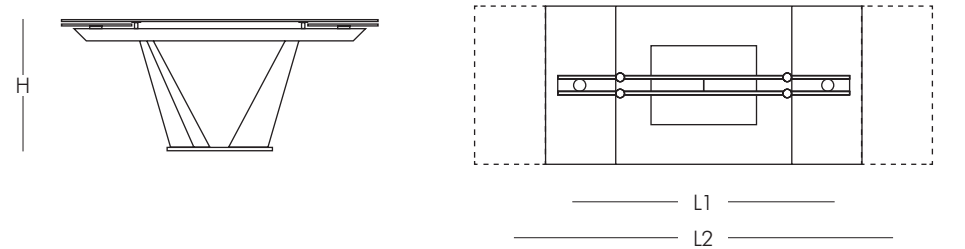

- | L1 | L2 | P |
|----------------------|----|---|
| • 160 → 240 x 100 cm | | |
| • 180 → 260 x 100 cm | | |
| • 200 → 280 x 100 cm | | |
| H: 75 cm | | |

TAVOLO DA PRANZO ESTENSIBILE, CON PIANO E PROLUNGHE IN CRISTALLO. BASE E BINARI IN METALLO CROMATO O VERNICIATO. DOTATO DI UN AGEVOLE MECCANISMO BREVETTATO, PER ESTRARRE LE PROLUNGHE LATERALI CHE CONSENTE DI AMPLIARE IL PIANO DI CM 80. DISPONIBILE IN UN'AMPIA GAMMA DI MISURE.

EXTENSIBLE DINING TABLE, WITH TOP AND EXTENSIONS OF GLASS. BASE AND TRACK OF CHROMED OR PAINTED METAL. A VERY EASY PATENTED MECHANISM TO PULL OUT THE LATERAL EXTENSIONS ALLOWS THE WIDENING OF THE TOP OF CM 80. AVAILABLE IN A LARGE RANGE OF SIZES.

TABLE REPAS EXTENSIBLE AVEC PLATEAU ET RALLONGES EN VERRE. BASE ET RAILS EN METAL CHROME' OU LAQUÉ. EQUIPEE D'UN MÉCANISME BREVETE' TRÈS A'L'AISE QUI PERMET AUX RALLONGES DE S'ÉTENDRE ET DE PROLONGER LA SURFACE DE CM 80. VASTE GAMME DE DIMENSIONS.

AUSZIEHBARER ESSTISCH MIT PLATTE UND AUSZÜGEN AUS KRISTALLGLAS. BASIS UND GLEISE AUS METALL, VERCHROMT ODER LACKIERT. EINEN BEQUEMEN PATENTIERTEN MECHANISMUS FÜR DIE SEITENAUSZÜGE ERLAUBT ES DEN TISCH UM CM 80 ZU VERGRÖßERN. ERHÄLTICH IN EINER BREITEN PALETTE VON GRÖßEN.

FEELING *VariActions*



BASE & SUPPORTS 10 MATT WHITE - TOPS 08 EXTRALIGHT GLASS



BASE SUPPORTS & MECHANISM 2525 MANGANESE - TOPS STONE SAVOIA PERLA



BASE SUPPORTS & MECHANISM 31BR BRONZO CHAMPAGNE - TOPS BLACK DESIRE

HELP *design Y. Hatano*

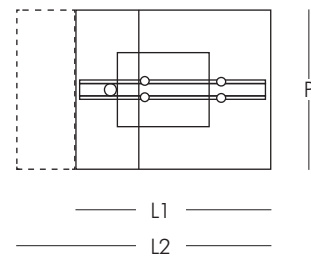
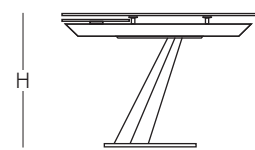

- L1 L2 P
- 140 → 180 x 80 cm
- H: 75 cm

TAVOLO ESTENSIBILE STUDIATO PER SPAZI RIDOTTI. PIANO E PROLUNGA IN CRISTALLO. BASE E BINARI IN METALLO CROMATO O VERNICIATO. DOTATO DI UN ESCLUSIVO MECCANISMO, PER ESTRARRE LA PROLUNGA LATERALE ED AMPLIARE IL PIANO DI 40CM.

TABLE REPAS EXTENSIBLE, IDÉALE POUR LES ESPACES RÉDUITS. PLATEAU ET RALLONGE EN VERRE. PIÈTEMENT ET RAIL EN METAL LAQUE OU CHROME'. UN MÉCANISME EXCLUSIF PERMET D'OUVRIR LA RALLONGE ET DE PROLONGER LA SURFACE DE 40 CM.

EXTENSIBLE DINING TABLE IDEAL FOR SMALL SPACES. TOP AND EXTENSION IN GLASS. BASE AND TRACK OF PAINTED OR CHROMED METAL. A VERY EASY MECHANISM TO PULL OUT THE LATERAL EXTENSION ALLOWS THE WIDENING OF THE TOP OF 40 CM.

AUSZIEHBARER ESSTISCH GEEIGNET FÜR KLEINE RÄUME. PLATTE UND AUSZUG AUS KRISTALLGLAS. BASIS UND GLEISE AUS METALL LACKIERT ODER VERCHROMT. EINEN BEQUEMEN MECHANISMUS FÜR DER SEITENAUSZUG ERLAUBT ES DEN TISCH UM 40 CM ZU VERGRÖßERN.

HELP *VariActions*



BASE SUPPORT & MECHANISM 37 CHROME - TOPS 08 EXTRALIGHT GLASS



BASE SUPPORT & MECHANISM 37 CHROME - TOPS STONE SAVOIA ANTRACITE



BASE SUPPORT & MECHANISM 31BR BRONZO CHAMPAGNE - TOPS BLACK DESIRE



TURNING

REVOLVING MUSE

TURNING ROUND/SQUARE *design A. Casati*

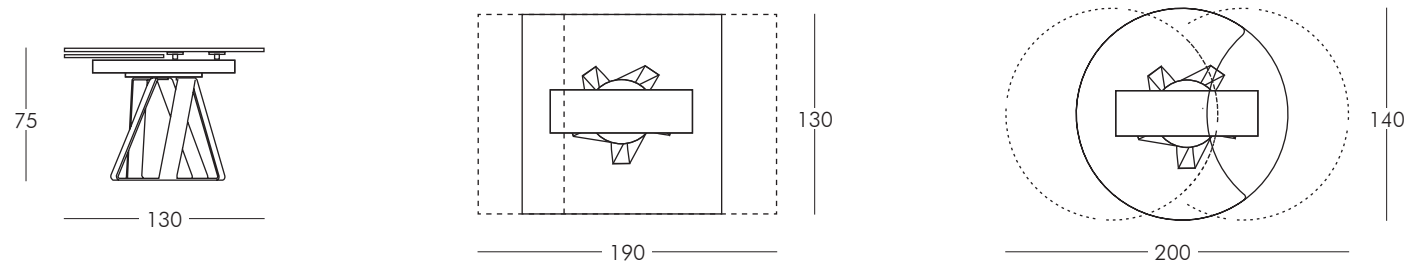

TAVOLO DA PRANZO ESTENSIBILE CON PIANI IN CRISTALLO VERNICIATO O CERAMICA. UN ORIGINALE MECCANISMO CONSENTE, ATTRAVERSO LA SOLA ROTAZIONE DEL CRISTALLO CENTRALE, DI ESTENDERE IL PIANO INFERIORE E LIVELLARLO AL PIANO SUPERIORE. BASE IN ACCIAIO VERNICIATO O GALVANIZZATO. SOLO PER ALCUNI TIPI DI CERAMICA E' POSSIBILE AVERE IL PIANO SUPERIORE IN LASTRA UNICA; CON TUTTI GLI ALTRI TIPI DI CERAMICA IL PIANO SUPERIORE E' FORMATO DA 2 LASTRE ACCOPPIATE.

EXTENSIBLE DINING TABLE WITH PAINTED GLASS TOPS OR CERAMIC. AN ORIGINAL OPENING MECHANISM ALLOWS, BY THE ROTATION OF THE CENTRAL TOP TO EXTEND THE LOWER TOP AND LEVEL IT TO THE UPPER TOP. BASE IN PAINTED OR GALVANISED STEEL. ONLY CERTAIN CERAMICS ALLOW THE UPPER TOP TO BE MADE OF ONE SOLE CERAMIC SHEET: ALL THE OTHER CERAMICS THE UPPER TOP IS MADE OF 2 MATCHING SHEET.

TABLE DE REPAS ALLONGEABLE AVEC PLATEAUX VERRE LAQUE' OU CERAMIQUE. UN MECANISME TRES ORIGINAL PERMET, PAR LA ROTATION DU PLATEAU CENTRALE, D'ETENDRE LE PLATEAU INFERIEUR ET LE NIVELER AU PLATEAU SUPERIEUR. PIED EN ACIER LAQUE' OU TRAITÉ AU BAIN GALVANIQUE. SEULEMENT POUR CERTAINES TYPES DE CERAMIQUE IL EST POSSIBLE D'AVOIR LE PLATEAU PRINCIPAL EN PANNEAU ENTIER. TOUS LES AUTRES SONT COMPOSES PAR 2 PANNEAUX ACCOUPLES.

AUSZIEHBARER ESSTISCH MIT PLATTEN AUS LACKIERTEM GLAS ODER KERAMIK. EIN ORIGINALER MECHANISMUS ERLAUBT MITTELS EINER EINZIGEN DREHUNG DER ZENTRALPLATTE, DIE UNTENPLATTE ZU ERLÄNGERN UND MIT DER OBERPLATTE ZU PLANIEREN. GESTELL AUS LACKIERTEM UND VERZINKTEM STAHL. NUR FÜR BESTIMMTEN KERAMIKTYPEN IST ES MÖGLICH DIE OBERPLATTE MIT EINER EINZELPLATTE ZU HABEN; FÜR DIE SONSTIGEN KERAMIKTYPEN BESTEHT DIE OBERPLATTE AUS 2 GEKOPPELTEN PLATTEN.

TURNING *VariActions*



ROUND - FRAME 34 NICKEL SATIN - MECHANISM 48 SHINY BRUSHED ALUM - TOPS STONE SAVOIA PERLA



ROUND - FRAME & MECHANISM 44 ANTRACITE - TOPS CALACATTA



SQUARE - FRAME & MECHANISM 5310 TAUPE - TOPS STATUARIO



ROUND/SQUARE

COLLECTION



PIANO FISSO
FIX TOP
PLATEAU FIX
FIX PLATTE

Ø 140 cm
Ø 160 cm

140 x 140 cm
160 x 160 cm

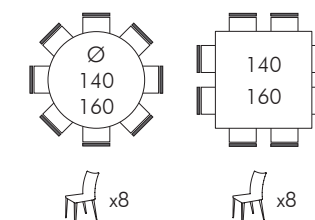

PIANO ESTENSIBILE
EXTENSIBLE TOP
PLATEAU ALLONGEABLE
AUSZIEHBARER PLATTE

100 x 160 → Ø 160 cm

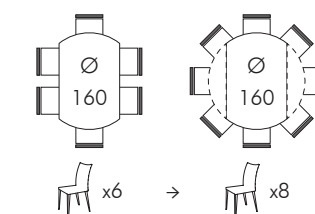

PIANO ESTENSIBILE
EXTENSIBLE TOP
PLATEAU ALLONGEABLE
AUSZIEHBARER PLATTE

100 x 160 → 160 x 160 cm

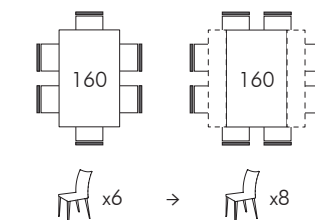

PIANO ESTENSIBILE
EXTENSIBLE TOP
PLATEAU ALLONGEABLE
AUSZIEHBARER PLATTE

100 x 180 → Ø 180 cm

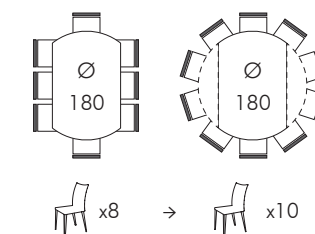

PLIÈ ROUND/SQUARE *design A. Casati*

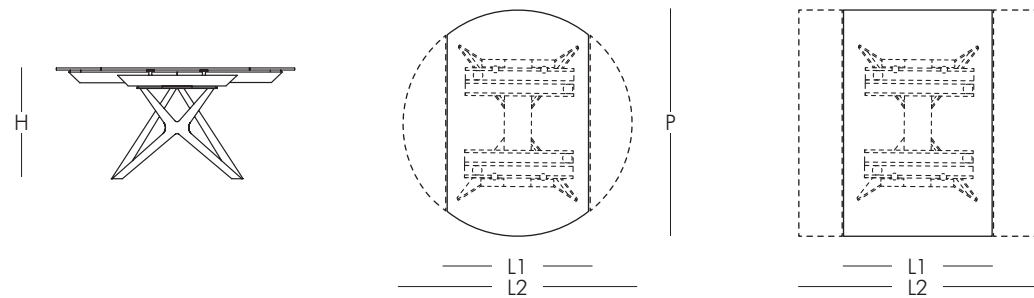

TAVOLO DA PRANZO ESTENSIBILE, CON PIANO IN CERAMICA. BASE E BINARI IN METALLO VERNICIATO. DOTATO DI UN AGEVOLE MECCANISMO BREVETTATO, PER ESTRARRE LE PROLUNGHE LATERALI CHE CONSENTE DI AMPLIARE IL PIANO DI CM 80.

EXTENSIBLE DINING TABLE, WITH TOP AND EXTENSIONS OF CERAMIC. BASE AND TRACK OF PAINTED METAL. A VERY EASY PATENTED MECHANISM TO PULL OUT THE LATERAL EXTENSIONS ALLOWS THE WIDENING OF THE TOP OF CM 80.

TABLE REPAS EXTENSIBLE AVEC PLATEAU ET RALLONGES EN CERAMIQUE. BASE ET RAILS EN METAL LAQUÉ. EQUIPEE D'UN MÉCANISME BREVETE' TRÈS A'L'AISE QUI PERMET AUX RALLONGES DE S'ÉTENDRE ET DE PROLONGER LA SURFACE DE CM 80.

- FIX TOP • L2 P
• 140 x 140 / 160 x 160 cm
• Ø 140 cm / Ø 160 cm
- EXTENSIBLE TOP • L1 P L2/P
• 100 x 160 → Ø 160 cm
• 100 x 180 → Ø 180 cm
• 100 x 160 → 160 x 160 cm
H: 75 cm

AUSZIEHBARER ESSTISCH MIT PLATTE UND AUSZÜGEN AUS KERAMIK. GLEISE AUS METALL LACKIERT. EINEN BEQUEMEN PATENTIERTEN MECHANISMUS FÜR DIE SEITENAUSZÜGE ERLAUBT ES DEN TISCH UM CM 80 ZU VERGRÖßERN.

PLIÈ *VariActions*



ROUND FRAME & MECHANISM 10 MATT WHITE - TOPS STONE SAVOIA GRIGIO



SQUARE - FRAME & MECHANISM 31BR BRONZO CHAMPAGNE - TOPS STATUARIO



SQUARE - FRAME & MECHANISM 2525 MANGANESE - TOPS BLACK DESIRE

SOMNIA ROUND/SQUARE design A. Casati

SOMNIA VariActions



ROUND - FRAME & MECHANISM 11 MATT BLACK - TOPS STONE FOKOS SALE



SQUARE - FRAME & MECHANISM 44 ANTRASCURO - TOPS STONE SAVOIA ANTRACITE



SQUARE - FRAME & MECHANISM 5320 CAPPUCCINO - TOPS PIETRA GREY

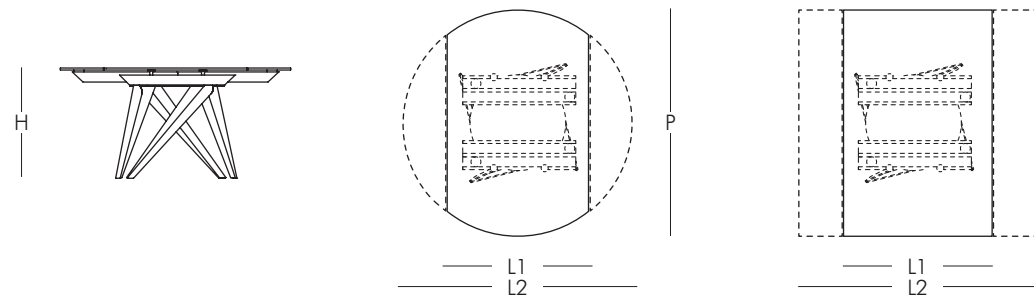

- FIX TOP • L2 P
• 140 x 140 / 160 x 160 cm
• Ø 140 cm / Ø 160 cm
- EXTENSIBLE TOP • L1 P L2/P
• 100 x 160 → Ø 160 cm
• 100 x 180 → Ø 180 cm
• 100 x 160 → 160 x 160 cm
H: 75 cm

TAVOLO DA PRANZO ESTENSIBILE, CON PIANO IN CERAMICA. BASE E BINARI IN METALLO VERNICIATO. DOTATO DI UN AGEVOLE MECCANISMO BREVETTATO, PER ESTRARRE LE PROLUNGHE LATERALI CHE CONSENTE DI AMPLIARE IL PIANO DI CM 80.

EXTENSIBLE DINING TABLE, WITH TOP AND EXTENSIONS OF CERAMIC. BASE AND TRACK OF PAINTED METAL. A VERY EASY PATENTED MECHANISM TO PULL OUT THE LATERAL EXTENSIONS ALLOWS THE WIDENING OF THE TOP OF CM 80.

TABLE REPAS EXTENSIBLE AVEC PLATEAU ET RALLONGES EN CERAMIQUE. BASE ET RAILS EN METAL LAQUÉ. EQUIPEE D'UN MÉCANISME BREVETE' TRÈS A'L'AISE QUI PERMET AUX RALLONGES DE S'ÉTENDRE ET DE PROLONGER LA SURFACE DE CM 80.

AUSZIEHBARER ESSTISCH MIT PLATTE UND AUSZÜGEN AUS KERAMIK. GLEISE AUS METALL LACKIERT. EINEN BEQUEMEN PATENTIERTEN MECHANISMUS FÜR DIE SEITENAUSZÜGE ERLAUBT ES DEN TISCH UM CM 80 ZU VERGRÖßERN.

BIG PLIÈ *design A. Casati*

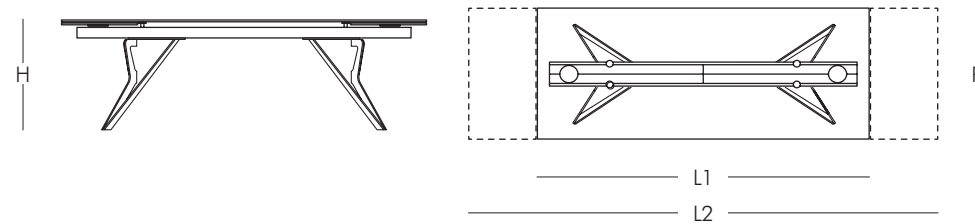

- | L1 | L2 | P |
|-------------|-------|----|
| • 240 → 340 | x 100 | cm |
| • 260 → 360 | x 100 | cm |
| • 280 → 380 | x 100 | cm |
| • 300 → 400 | x 100 | cm |
- H: 75 cm

THE GIANTS È LA NUOVA COLLEZIONE DI TAVOLI ALLUNGABILI DI GRANDI DIMENSIONI. LO SPECIALE MECCANISMO NAOS PERMETTE, TRAMITE LE DUE PROLUNGHE, L'ALLUNGAMENTO DEL PIANO DI 100 CM (50 CM CIASCUNA). LA DIMENSIONE MINIMA DEL TAVOLO CHIUSO È 240 CM PER ARRIVARE A 400 CM APERTO. PIANO DISPONIBILE IN VETRO O IN CERAMICA. GAMBE IN METALLO VERNICIATO.

THE GIANTS IS THE NEW COLLECTION OF EXTENSIBLE BIG TABLES. SPECIAL NAOS MECHANISM ALLOWS, BY THE TWO EXTENSIONS, THE WIDENING OF THE TOP OF 100 CM (50 CM EACH). THE MINIMUM SIZE OF THE TABLE IS 240 CM CLOSED TO 400 CM OPENED. TOP AVAILABLE IN GLASS OR IN STONE AND PORCELAIN CERAMIC COLLECTION. LEGS IN PAINTED METAL.

THE GIANTS EST LA NOUVELLE COLLECTION DE GRANDES TABLES EXTENSIBLES. LE MÉCANISME SPÉCIAL NAOS PERMET, PAR LES DEUX ALLONGES, L'EXTENSION DU PLATEAU DE 100 CM (50 CM CHACUNE). LA DIMENSION MINIMUM DE LA TABLE PASSE DE 240 CM FERMÉE À 400 CM OUVERTE. PLATEAU DISPONIBLE EN VERRE OU DANS DANS TOUTES LES FINITIONS CÉRAMIQUE. PIEDS EN METAL LAQUE'.

THE GIANTS IST DIE NEUE KOLLEKTION DER GROSSEN AUSZIEHBAREN ESSTISCHE. EIN SPEZIELLER NAOS-MECHANISMUS ERMÖGLICHT, DURCH DIE BEIDEN VERLÄNGERUNGEN, DIE VERBREITERUNG DER OBERSEITE VON 100 CM (50 CM). DIE MINIMUM GRÖSSE DES ESSTISCHES BETRÄGT 240 CM GESCHLOSSEN UND BIS 400 CM GEÖFFNET. DIE PLATTE IST IN GLAS ODER IN KERAMIK ERHAELTICH. GESTELL IN LACKIERTEN METALL.

BIG PLIÈ *VariActions*



LEGS & MECHANISM 31BR BRONZO CHAMPAGNE - TOPS CALACATTA



LEGS & MECHANISM 7044 SAND - TOPS BLACK GRECO



240 → 340 x 100 cm

x 8 → 12



300 → 400 x 100 cm

x 12 → 16

DISPONIBILE ANCHE NELLE MISURE STANDARD
ALSO AVAILABLE IN STANDARD SIZES
ÉGALEMENT DISPONIBLE EN TAILLES STANDARDS
AUCH IN STANDARDGRÖSSEN ERHÄLTICH

- | L1 | L2 | P |
|-----------|-------|----|
| 180 → 260 | x 100 | cm |
| 200 → 280 | x 100 | cm |
| 220 → 300 | x 100 | cm |

INGENTS



INGENTS *design Naos*

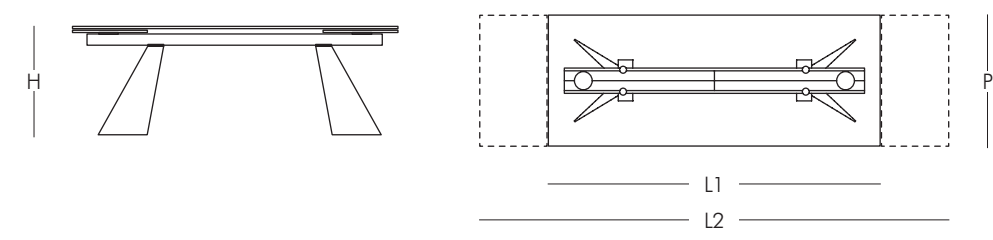

- | L1 | L2 | P |
|----------------------|----|---|
| • 240 → 340 x 100 cm | | |
| • 260 → 360 x 100 cm | | |
| • 280 → 380 x 100 cm | | |
| • 300 → 400 x 100 cm | | |
| H: 75 cm | | |

THE GIANTS È LA NUOVA COLLEZIONE DI TAVOLI ALLUNGABILI DI GRANDI DIMENSIONI. LO SPECIALE MECCANISMO NAOS PERMETTE, TRAMITE LE DUE PROLUNGHE, L'ALLUNGAMENTO DEL PIANO DI 100 CM (50 CM CIASCUNA). LA DIMENSIONE MINIMA DEL TAVOLO CHIUSO È 240 CM PER ARRIVARE A 400 CM APERTO. PIANO DISPONIBILE IN VETRO O IN CERAMICA. GAMBE IN METALLO VERNICIATO O CROMATE.

THE GIANTS IS THE NEW COLLECTION OF EXTENSIBLE BIG TABLES. SPECIAL NAOS MECHANISM ALLOWS, BY THE TWO EXTENSIONS, THE WIDENING OF THE TOP OF 100 CM (50 CM EACH). THE MINIMUM SIZE OF THE TABLE IS 240 CM CLOSED TO 400 CM OPENED. TOP AVAILABLE IN GLASS OR IN STONE AND PORCELAIN CERAMIC COLLECTION. LEGS IN PAINTED METAL OR CHROME PLATE COLOR RANGE.

THE GIANTS EST LA NOUVELLE COLLECTION DE GRANDES TABLES EXTENSIBLES. LE MÉCANISME SPÉCIAL NAOS PERMET, PAR LES DEUX ALLONGES, L'EXTENSION DU PLATEAU DE 100 CM (50 CM CHACUNE). LA DIMENSION MINIMUM DE LA TABLE PASSE DE 240 CM FERMÉE À 400 CM OUVERTE. PLATEAU DISPONIBLE EN VERRE OU DANS DANS TOUTES LES FINITIONS CÉRAMIQUE. PIEDS EN MÉTAL LAQUE' OU CHROME'.

THE GIANTS IST DIE NEUE KOLLEKTION DER GROSSEN AUSZIEHBAREN ESSTISCHE. EIN SPEZIELLER NAOS-MECHANISMUS ERMÖGLICHT, DURCH DIE BEIDEN VERLÄNGERUNGEN, DIE VERBREITERUNG DER OBERSEITE VON 100 CM (50 CM). DIE MINIMUM GRÖSSE DES ESSTISCHES BETRÄGT 240 CM GESCHLOSSEN UND BIS 400 CM GEÖFFNET. DIE PLATTE IST IN GLAS ODER IN KERAMIK ERHAELTLICH. GESTELL IN LACKIERTEN METALL ODER VERCHROMT.



240 → 340 x 100 cm

x 8 → 12



300 → 400 x 100 cm

x 12 → 16

DISPONIBILE ANCHE NELLE MISURE STANDARD
ALSO AVAILABLE IN STANDARD SIZES
ÉGALEMENT DISPONIBLE EN TAILLES STANDARDS
AUCH IN STANDARDGRÖSSEN ERHÄTLICH

- | L1 | L2 | P |
|--------------------|----|---|
| 180 → 260 x 100 cm | | |
| 200 → 280 x 100 cm | | |
| 220 → 300 x 100 cm | | |

INGENTS *VariActions*



LEGS & MECHANISM 7016 MATT ANTRACITE - TOPS STONE SAVOIA PERLA



LEGS 33 BLACK NICKEL - MECHANISM 11 MATT BLACK - TOPS BLACK DESIRE

CONVIVIUM



CONVIVIUM *design Naos*

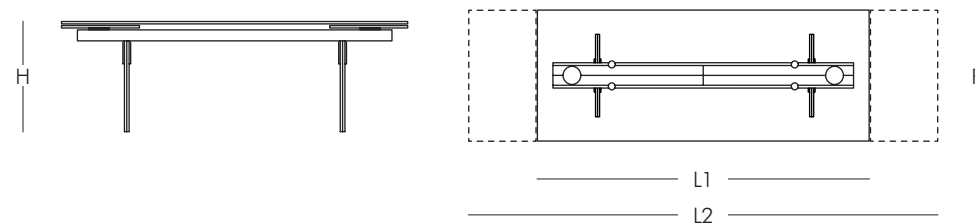

- | L1 | L2 | P |
|----------------------|----|---|
| • 240 → 340 x 100 cm | | |
| • 260 → 360 x 100 cm | | |
| • 280 → 380 x 100 cm | | |
| • 300 → 400 x 100 cm | | |
- H: 75 cm

THE GIANTS È LA NUOVA COLLEZIONE DI TAVOLI ALLUNGABILI DI GRANDI DIMENSIONI. LO SPECIALE MECCANISMO NAOS PERMETTE, TRAMITE LE DUE PROLUNGHE, L'ALLUNGAMENTO DEL PIANO DI 100 CM (50 CM CIASCUNA). LA DIMENSIONE MINIMA DEL TAVOLO CHIUSO È 240 CM PER ARRIVARE A 400 CM APERTO. PIANO E GAMBE DISPONIBILI IN VETRO O IN CERAMICA.

THE GIANTS IS THE NEW COLLECTION OF EXTENSIBLE BIG TABLES. SPECIAL NAOS MECHANISM ALLOWS, BY THE TWO EXTENSIONS, THE WIDENING OF THE TOP OF 100 CM (50 CM EACH). THE MINIMUM SIZE OF THE TABLE IS 240 CM CLOSED TO 400 CM OPENED. TOP AND LEGS AVAILABLE IN GLASS OR IN STONE AND PORCELAIN CERAMIC COLLECTION.

THE GIANTS EST LA NOUVELLE COLLECTION DE GRANDES TABLES EXTENSIBLES. LE MÉCANISME SPÉCIAL NAOS PERMET, PAR LES DEUX ALLONGES, L'EXTENSION DU PLATEAU DE 100 CM (50 CM CHACUNE). LA DIMENSION MINIMUM DE LA TABLE PASSE DE 240 CM FERMÉE À 400 CM OUVERTE. PLATEAU ET PIEDS DISPONIBLES EN VERRE OU DANS DANS TOUTES LES FINITIONS CÉRAMIQUE.

THE GIANTS IST DIE NEUE KOLLEKTION DER GROSSEN AUSZIEHBAREN ESSTISCHE. EIN SPEZIELLER NAOS-MECHANISMUS ERMÖGLICHT, DURCH DIE BEIDEN VERLÄNGERUNGEN, DIE VERBREITERUNG DER OBERSEITE VON 100 CM (50 CM). DIE MINIMUM GRÖSSE DES ESSTISCHES BETRÄGT 240 CM GESCHLOSSEN UND BIS 400 CM GEÖFFNET. PLATTEN UND GESTELL AUS GLAS ODER KERAMIK.

CONVIVIUM *VariActions*



LEGS BLACK DESIRE - MECHANISM 11 MATT BLACK - TOPS BLACK DESIRE



LEGS STONE SAVOIA GRIGIO - MECHANISM 11 MATT BLACK - TOPS STONE SAVOIA GRIGIO



240 → 340 x 100 cm

x 8 → 12



300 → 400 x 100 cm

x 12 → 16

DISPONIBILE ANCHE NELLE MISURE STANDARD
ALSO AVAILABLE IN STANDARD SIZES
ÉGALEMENT DISPONIBLE EN TAILLES STANDARDS
AUCH IN STANDARDGRÖSSEN ERHÄLTICH

L1	L2	P
180 → 260 x 100 cm		
200 → 280 x 100 cm		
220 → 300 x 100 cm		

EQUUS



EQUUS *design Naos*

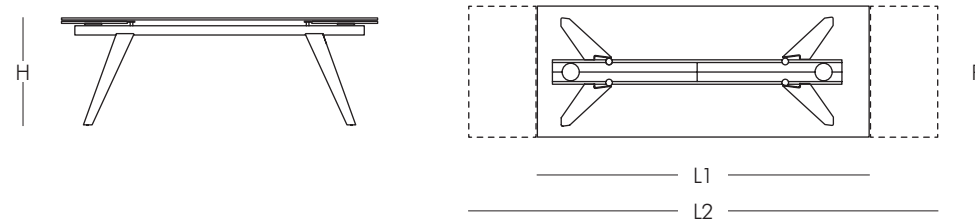

- | L1 | L2 | P |
|----------------------|----|---|
| • 240 → 340 x 100 cm | | |
| • 260 → 360 x 100 cm | | |
| • 280 → 380 x 100 cm | | |
| • 300 → 400 x 100 cm | | |
| H: 75 cm | | |

THE GIANTS È LA NUOVA COLLEZIONE DI TAVOLI ALLUNGABILI DI GRANDI DIMENSIONI. LO SPECIALE MECCANISMO NAOS PERMETTE, TRAMITE LE DUE PROLUNGHE, L'ALLUNGAMENTO DEL PIANO DI 100 CM (50 CM CIASCUNA). LA DIMENSIONE MINIMA DEL TAVOLO CHIUSO È 240 CM PER ARRIVARE A 400 CM APERTO. PIANO DISPONIBILE IN VETRO O IN CERAMICA. GAMBE IN METALLO VERNICIATO O CROMATE.

THE GIANTS IS THE NEW COLLECTION OF EXTENSIBLE BIG TABLES. SPECIAL NAOS MECHANISM ALLOWS, BY THE TWO EXTENSIONS, THE WIDENING OF THE TOP OF 100 CM (50 CM EACH). THE MINIMUM SIZE OF THE TABLE IS 240 CM CLOSED TO 400 CM OPENED. TOP AVAILABLE IN GLASS OR IN STONE AND PORCELAIN CERAMIC COLLECTION. LEGS IN PAINTED METAL OR CHROME PLATE COLOR RANGE.

THE GIANTS EST LA NOUVELLE COLLECTION DE GRANDES TABLES EXTENSIBLES. LE MÉCANISME SPÉCIAL NAOS PERMET, PAR LES DEUX ALLONGES, L'EXTENSION DU PLATEAU DE 100 CM (50 CM CHACUNE). LA DIMENSION MINIMUM DE LA TABLE PASSE DE 240 CM FERMÉE À 400 CM OUVERTE. PLATEAU DISPONIBLE EN VERRE OU DANS DANS TOUTES LES FINITIONS CÉRAMIQUE. PIEDS EN MÉTAL LAQUE' OU CHROME'.

THE GIANTS IST DIE NEUE KOLLEKTION DER GROSSEN AUSZIEHBAREN ESSTISCHE. EIN SPEZIELLER NAOS-MECHANISMUS ERMÖGLICHT, DURCH DIE BEIDEN VERLÄNGERUNGEN, DIE VERBREITERUNG DER OBERSEITE VON 100 CM (50 CM). DIE MINIMUM GRÖSSE DES ESSTISCHES BETRÄGT 240 CM GESCHLOSSEN UND BIS 400 CM GEÖFFNET. DIE PLATTE IST IN GLAS ODER IN KERAMIK ERHAELTLICH. GESTELL IN LACKIERTEN METALL ODER VERCHROMT.



240 → 340 x 100 cm

x 8 → 12



300 → 400 x 100 cm

x 12 → 16

DISPONIBILE ANCHE NELLE MISURE STANDARD
ALSO AVAILABLE IN STANDARD SIZES
ÉGALEMENT DISPONIBLE EN TAILLES STANDARDS
AUCH IN STANDARDGRÖSSEN ERHÄLTICH

L1	L2	P
180 → 260 x 100 cm		
200 → 280 x 100 cm		
220 → 300 x 100 cm		

EQUUS *VariActions*



LEGS 33 BLACK NICKEL - MECHANISM 11 MATT BLACK - TOPS STONE SAVOIA GRIGIO



LEGS 570 SMOKE - MECHANISM 11 MATT BLACK - TOPS BLACK DESIRE

INGENIOUS MUSES

UNCONVENTIONAL
COFFEE TABLES



COFFEE TABLES

COLLECTION



CALYPSO - PAG 127



CASSIUS - PAG 133



MYFLOWERS - PAG 137



MADISON - PAG 143



ABRA / OCTAGO - PAG 149



CADABRA - PAG 155



AQUILYPS - PAG 159



AQUÌ - PAG 163



SAMURAI - PAG 167



HIVE - PAG 169



LES JEUX SONT FAITS - PAG 173



MAGELLANO / AMERIGO / COLOMBO - PAG 177



UPTOWN - PAG 189



BASALTO - PAG 195



DISCOVERY - PAG 201



GIROTONDO - PAG 205



BATIS - PAG 209



BLOSSOM - PAG 213



PETRES - PAG 215



AVIOR - PAG 217



MILES - PAG 219



GEMELLI - PAG 221



EXTREMIS - PAG 223



ANELLI / DONELLI - PAG 227



SINUOSO - PAG 229



THETA / THETA SHELF - PAG 233



SHEDIR - PAG 237



ALTAIR / PHOBOS - PAG 239

LAMP TABLES

COLLECTION



CALYPSO LAMP
PAG 131



CLAY
PAG 135



HARRY
PAG 151



LYPS
PAG 161



SAMURAI LAMP
PAG 167



BASALTO LAMP
PAG 199



DISCOVERY LAMP
PAG 203



GEMELLINO
PAG 221

CALYPSO

MYTHICAL MUSE





CALYPSO *design Y. Hatano*



CALYPSO *VariActions*



BASE 74 SMOKE MIRROR - SUPPORTS 33 BLACK NICKEL - TOPS 74 SMOKE GLASS



BASE STATUARIO - SUPPORTS 37 CHROME - TOPS STATUARIO

CALYPSO LAMP

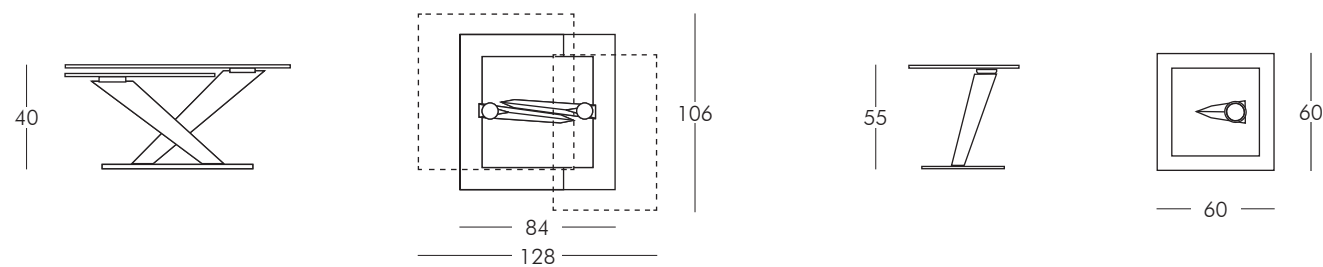

TAVOLINO ESTENSIBILE CON PIANI GIREVOLI SINCRONIZZATI IN CRISTALLO. BASE E SUPPORTI IN ACCIAIO VERNICIATO O GALVANIZZATO. DISPONIBILE ANCHE CON BASE IN CERAMICA, CRISTALLO VERNICIATO O SPECCHIO. PIANI DISPONIBILI IN CERAMICA.

EXTENSIBLE COCKTAIL TABLE WITH SYNCHRONISED REVOLVING GLASS TOPS. BASE AND SUPPORTS IN GALVANISED OR PAINTED STEEL. AVAILABE ALSO WITH CERAMICS, PAINTED GLASS OR MIRROR BASE. AVAILABLE CERAMICS TOPS.

TABLE DE SALON EXTENSIBLE AVEC PLATEAUX TOURNANTS-SYNCHRONISÉS EN VERRE. BASE ET SUPPORTS EN ACIER LAQUÉ OU GALVANISÉ. DISPONIBILE AUSSI AVEC SOCLE EN CERAMIQUE, EN VERRE LAQUE' OU EN MIRROIR. PLATEAUX DISPONIBLES EN CERAMIQUE.

AUSZIEHBARER COUCHTISCH MIT SYNCHRON DREHBAREN KRISTALLGLASPLATTEN. BASIS UND TRÄGER AUS LACKIERTEM ODER GALVANISIERTEM STAHL. LIEFERBAR AUCH MIT BASIS AUS KERAMIK, LACKERTEM GLASS.

CALYPSO LAMP

TAVOLINO ANGOLARE COORDINATO AL MODELLO CALYPSO.

CORNER TABLE IN MATCHING WITH CALYPSO COCKTAIL TABLE.

BOUT DE CANAPE ASSORTI À LA TABLE DE SALON CALYPSO.

PASSENDER BEISTELLTISCH IN GLEICHEN AUSFUHRUNGEN DES CALYPSO COUCHTISCH.



CASSIUS



CASSIUS *design A. Gamba L. Guerra*



CASSIUS *VariActions*



BASE 15 MIRROR - SUPPORTS 37 CHROME - TOPS CALACATTA / 08 EXTRALIGHT GLASS



BASE BLACK DESIRE - SUPPORTS 370 GOLD SHINY - TOPS BLACK DESIRE / 08 EXTRALIGHT GLASS

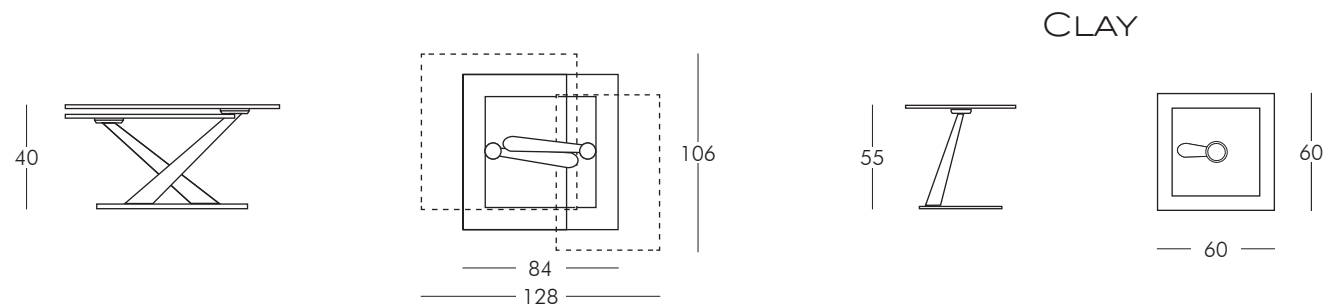

CLAY

CLAY

TAVOLINO ESTENSIBILE CON PIANI GIREVOLI SINCRONIZZATI IN CRISTALLO. BASE E SUPPORTI IN ACCIAIO VERNICIATO O GALVANIZZATO. DISPONIBILE ANCHE CON BASE IN CERAMICA, CRISTALLO VERNICIATO O SPECCHIO. PIANI DISPONIBILI IN CERAMICA.

EXTENSIBLE COCKTAIL TABLE WITH SYNCHRONISED REVOLVING GLASS TOPS. BASE AND SUPPORTS IN GALVANISED OR PAINTED STEEL. AVAILABE ALSO WITH CERAMICS, PAINTED GLASS OR MIRROR BASE. AVAILABLE CERAMICS TOPS.

TABLE DE SALON EXTENSIBLE AVEC PLATEAUX TOURNANTS-SYNCHRONISÉS EN VERRE. BASE ET SUPPORTS EN ACIER LAQUÉ OU GALVANIisé. DISPONIBILE AUSSI AVEC SOCLE EN CERAMIQUE, EN VERRE LAQUE' OU EN MIRROIR. PLATEAUX DISPONIBLES EN CERAMIQUE.

AUSZIEHBARER COUCHTISCH MIT SYNCHRON DREHBAREN KRISTALLGLASPLATTEN. BASIS UND TRÄGER AUS LACKIERTEM ODER GALVANISIERTEM STAHL. LIEFERBAR AUCH MIT BASIS AUS KERAMIK, LACKERTEM GLASS ODER SPIEGEL. PLATTEN AUS KERAMIK.

TAVOLINO ANGOLARE COORDINATO AL MODELLO CASSIUS.

CORNER TABLE MATCHING WITH CASSIUS COCKTAIL TABLE.

BOUT DE CANAPE ASSORTI À LA TABLE DE SALON CASSIUS.

PASSENDER BEISTELLTISCH IN GLEICHEN AUSFUHRUNGEN DES CASSIUS COUCHTISCH.





MYFLOWER

*BLOSSOMING
INSPIRATION*



MYFLOWER *design D. D'Urbino P. Lomazzi*

TAVOLINO ESTENSIBILE CON 3 PIANI GIREVOLI SINCRONIZZATI IN CRISTALLO O CERAMICA. LA PARTICOLARE GEOMETRIA DEI PIANI E DEL MECCANISMO PERMETTE AL TAVOLO IN POSIZIONE CHIUSA DI NASCONDERE I PIANI SOTTOSTANTI. BASE E SUPPORTI IN ACCIAIO VERNICIATO O CROMATO.

EXTENSIBLE COFFEE TABLE WITH 3 SYNCHRONIZED REVOLVING TOPS IN GLASS OR CERAMIC. THE PECULIAR TOPS AND MECHANISM GEOMETRY ALLOWS THE LOWER TOPS TO BE HIDDEN IN THE CLOSED POSITION. BASE AND SUPPORTS IN PAINTED OR CHROMED STEEL.

TABLE DE SALON EXTENSIBLE AVEC 3 PLATEAUX PIVOTANTS SYNCHRONISÉS EN VERRE OU CERAMIQUE. LA GÉOMETRIE SPÉCIFIQUE DES PLATEAUX ET DU MÉCANISME, PERMET DE CACHER, EN POSITION FERMÉE, LES PLATEAUX INFÉRIEURS. SOCLE ET SUPPORTS EN ACIER LAQUE' OU CHROME'.

AUSZIEHBARER COUCHTISCH MIT 3 SYNCHRONISIERTEN DREHBAREN PLATTEN AUS KRISTALLGLAS ODER KERAMIK. DIE BESONDERE GEOMETRIE DER PLATTEN UND MECHANISMUS ERLAUBT DER COUCHTISCH IN GESCHLOSSENER POSITION DIE UNTEREN PLATTEN ZU VERSTECKEN. BASIS UND TRÄGER AUS VERCHROMTEM ODER LACKIERTEM STAHL.

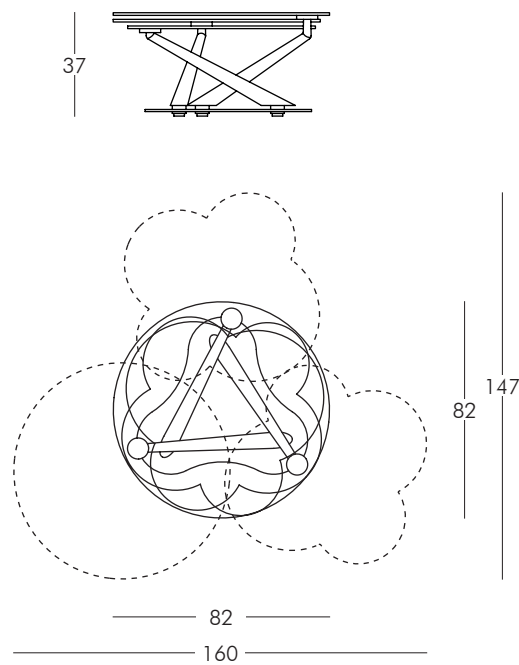

MADISON

*CONTEMPORARY
INSPIRATION*





MADISON *design A. Casati*

TAVOLINO ESTENSIBILE CON 4 PIANI IN CRISTALLO O CERAMICA. DOTATO DI UN INNOVATIVO DOPPIO MECCANISMO SINCRONIZZATO DI APERTURA CHE PERMETTE AI 4 CRISTALLI DI APRIRSI CON UN SOLO GESTO MA IN DIREZIONI OPPOSTE. SUPPORTI IN ACCIAIO VERNICIATO O CROMATO.

EXTENSIBLE COFFEE TABLE WITH 4 GLASS OR CERAMIC TOPS. EQUIPPED WITH AN INNOVATIVE DOUBLE SYNCHRONIZED MECHANISM THAT ALLOW THE 4 TOPS TO BE OPENED AT ONCE, WITH A SIMPLE GESTURE AND BE AT THE SAME TIME PLACED IN DIFFERENT DIRECTIONS. SUPPORTS IN PAINTED OR CHROMED STEEL.

TABLE DE SALON EXTENSIBLE AVEC 4 PLATEAUX EN VERRE OU CERAMIQUE. EQUIPÉE D'UN MÉCANISME SYNCHRONISÉ À DOUBLE EFFET, QUI PERMET L'OUVERTURE SIMULTANÉE DES 4 PLATEAUX, MAIS EN DIRECTIONS OPPOSÉES. SUPPORTS EN ACIER LAQUÉ OU CHROMÉ.

AUSZIEHBARER COUCHTISCH MIT 4 PLATTEN AUS KRISTALLGLAS ODER KERAMIK. AUSGESTATTET MIT EINER INNOVATIVEN SYNCHRONISIERTEN DOPPELMECHANISMUS, DIE MIT EINER EINZIGEN BEWEGUNG DIE 4 GLASPLATTEN ERLAUBT SICH ZU ÖFFNEN, ABER IN GEGENSÄTZLICHEN RICHTUNGEN. TRÄGER AUS VERCHROMTEM ODER LACKIERTEM STAHL.

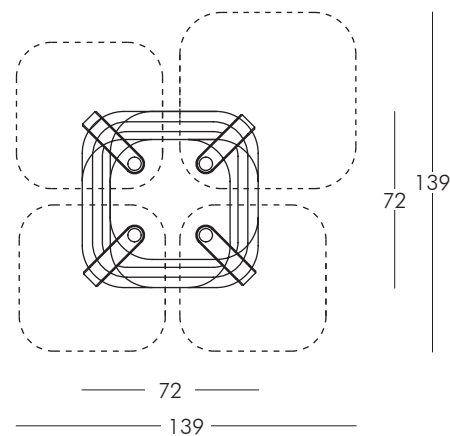
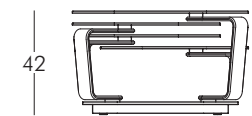

ABRA



ABRA *design A. Gamba L. Guerra*



ABRA *VariActions*



BASE & SUPPORTS 37 CHROME - TOPS STONE SAVOIA ANTRACITE / 00 NATURAL GLASS



BASE & SUPPORTS 37 CHROME - TOPS STONE SAVOIA GRIGIO

HARRY

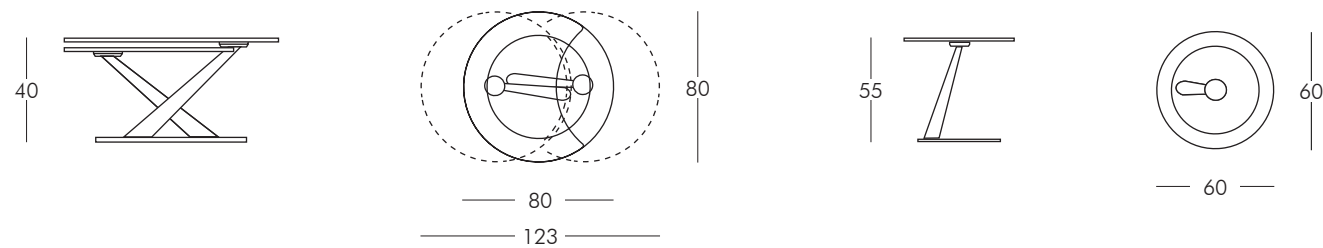

TAVOLINO ESTENSIBILE CON PIANI GIREVOLI SINCRONIZZATI IN CRISTALLO. BASE E SUPPORTI IN ACCIAIO VERNICIATO O GALVANIZZATO. LA BASE E' DOTATA DI UN MECCANISMO PER LA ROTAZIONE SINCRONIZZATA, CHE CONSENTE UN'AMPIA MODULAZIONE DELLA FORMA. DISPONIBILE ANCHE CON PIANI IN CERAMICA.

EXTENSIBLE COFFEE TABLE WITH SYNCHRONIZED REVOLVING CRYSTAL TOPS. BASE AND SUPPORTS IN PAINTED OR GALVANIZED STEEL. THE BASE IS EQUIPPED WITH A MECHANISM FOR THE SYNCHRONIZED ROTATION OF THE TOPS THAT ALLOWS AMPLE MODULATION OF THE FORM. AVAILABE ALSO WITH CERAMICS TOPS.

TABLE DE SALON EXTENSIBLE AVEC PLATEAUX TOURNANTS- SYNCHRONISÉS EN VERRE. PIÉTEMENT ET SUPPORTS EN ACIER LAQUÉ OU GALVANIÉ. LA BASE EST ÉQUIPÉE D'UN MÉCANISME DE ROTATION SYNCHRONISÉE QUI PERMET UNE AMPLE MODULATION DE LA FORME. DISPONIBILE AUSSI AVEC PLATEAUX EN CERAMIQUE.

AUSZIEHBARER COUCHTISCH MIT SYNCHRON DREHBAREN KRISTALLGLASPLATTEN. BASIS UND TRÄGER AUS LACKIERTEM ODER GALVANISIERTEM STAHL. DER BESONDERE MECHANISMUS ERLAUBT ES DEN PLATTEN VIELFÄLTIGE POSITIONEN EINZUNEHMEN. LIEFERBAR AUCH MIT KERAMIKPLATTEN.

HARRY

TAVOLINO ANGOLARE COORDINATO AL MODELLO ABRA.

CORNER TABLE MATCHING WITH ABRA COCKTAIL TABLE.

BOUT DE CANAPE ASSORTI À LA TABLE DE SALON ABRA.

PASSENDER BEISTELLTISCH IN GLEICHEN AUSFUHRUNGEN DES ABRA COUCHTISCH.



OCTAGO *design Naos*

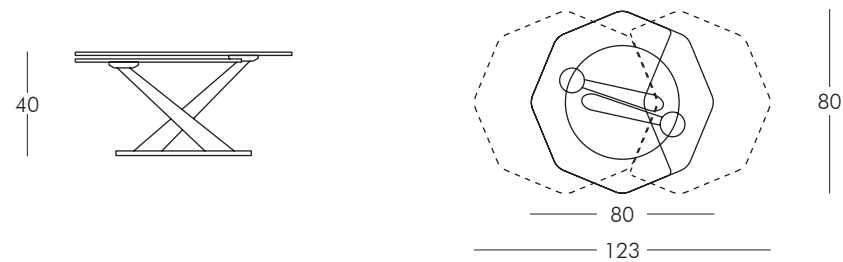

TAVOLINO ESTENSIBILE CON PIANI GIREVOLI SINCRONIZZATI IN CRISTALLO. BASE E SUPPORTI IN ACCIAIO VERNICIATO O GALVANIZZATO. LA BASE E' DOTATA DI UN MECCANISMO PER LA ROTAZIONE SINCRONIZZATA, CHE CONSENTE UN'AMPIA MODULAZIONE DELLA FORMA. DISPONIBILE ANCHE CON PIANI IN CERAMICA.

EXTENSIBLE COFFEE TABLE WITH SYNCHRONIZED REVOLVING TOPS IN GLASS. BASE AND SUPPORTS IN PAINTED OR GALVANIZED STEEL. THE BASE IS EQUIPPED WITH A MECHANISM FOR THE SYNCHRONIZED ROTATION OF THE TOPS THAT ALLOWS AMPLE MODULATION OF THE SHAPE. AVAILABE ALSO WITH CERAMICS TOPS.

TABLE DE SALON EXTENSIBLE AVEC PLATEAUX TOURNANTS- SYNCHRONISES EN VERRE. PIETEMENT ET SUPPORTS EN ACIER LAQUE OU GALVANISE. LA BASE EST EQUIPEE D'UN MECANISME DE ROTATION SYNCHRONISEE QUI PERMET UNE GRANDE VARIÉTÉ DE POSITIONS. DISPONIBILE AUSSI AVEC PLATEAUX EN CERAMIQUE.

AUSZIEHBARER COUCHTISCH MIT SYNCHRON DREHBAREN KRISTALLGLASPLATTEN. BASIS UND TRÄGER AUS LACKIERTEM ODER GALVANISIERTEM STAHL. DER BESONDERE MECHANISMUS ERLAUBT ES DEN PLATTEN VIELFÄLTIGE POSITIONEN EINZUNEHMEN. LIEFERBAR AUCH MIT KERAMIKPLATTEN.

OCTAGO *VariActions*



BASE & SUPPORTS 37 CHROME - TOPS CALACATTA / 00 NATURAL GLASS



BASE & SUPPORTS 37 CHROME - TOPS STONE SAVOIA ANTRACITE / 74 SMOKE



BASE 11 MATT BLACK - SUPPORTS 370 COPPER - TOPS SAHARA NOIR

CADABRA



CADABRA *design A. Gamba L. Guerra*

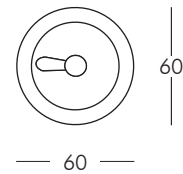
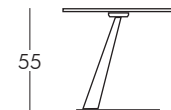
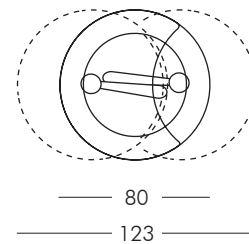
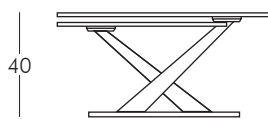

HARRY

TAVOLINO ESTENSIBILE CON PIANI GIREVOLI SINCRONIZZATI IN CRISTALLO. SUPPORTI IN ACCIAIO VERNICIATO O GALVANIZZATO. DISPONIBILE CON BASE IN CERAMICA, CRISTALLO VERNICIATO O SPECCHIO. PIANI DISPONIBILI IN CERAMICA.

EXTENSIBLE COCKTAIL TABLE WITH SYNCHRONISED REVOLVING GLASS TOPS. SUPPORTS IN GALVANISED OR PAINTED STEEL. AVAILABE WITH CERAMICS, PAINTED GLASS OR MIRROR BASE. AVAILABLE CERAMICS TOPS.

TABLE DE SALON EXTENSIBLE AVEC PLATEAUX TOURNANTS-SYNCHRONISÉS EN VERRE. SUPPORTS EN ACIER LAQUÉ OU GALVANISÉ. DISPONIBILE AVEC SOCLE EN CERAMIQUE, EN VERRE LAQUE' OU EN MIRROIR. PLATEAUX DISPONIBLES EN CERAMIQUE.

AUSZIEHBARER COUCHTISCH MIT SYNCHRON DREHBAREN KRISTALLGLASPLATTEN. TRÄGER AUS LACKIERTEM ODER GALVANISIERTEM STAHL. LIEFERBAR MIT BASIS AUS KERAMIK, LACKERTEM GLASS ODER SPIEGEL. PLATTEN AUS KERAMIK.

CADABRA *VariActions*



BASE CALACATTA - SUPPORTS 37 CHROME - TOPS CALACATTA / 00 NATURAL GLASS



BASE 66 WHITE GLASS - SUPPORTS 10 MATT WHITE - TOPS STONE SAVOIA PERLA

HARRY

TAVOLINO ANGOLARE COORDINATO AL MODELLO CADABRA.

CORNER TABLE MATCHING WITH CADABRA COCKTAIL TABLE.

BOUT DE CANAPE ASSORTI À LA TABLE DE SALON CADABRA.

PASSENDER BEISTELLTISCH IN GLEICHEN AUSFUHRUNGEN DES CADABRA COUCHTISCH.



AQUILYPS



AQUILYPS *design Y. Hatano*

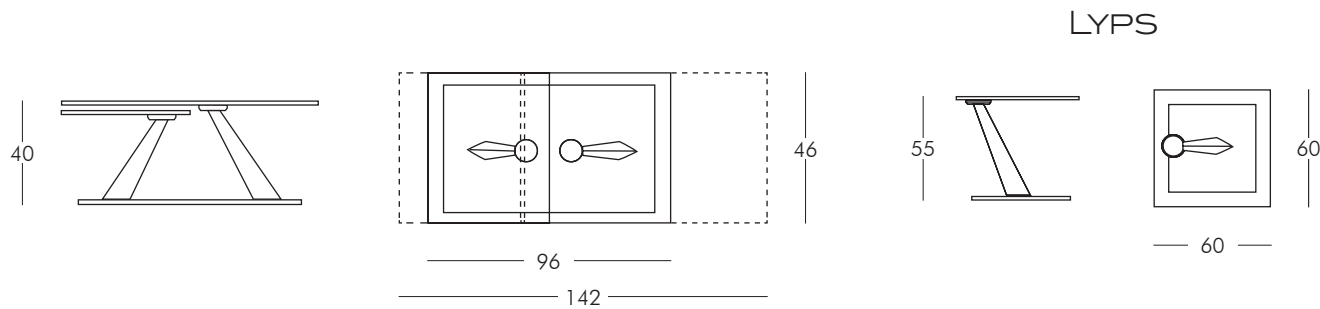

TAVOLINO ESTENSIBILE CON PIANI IN CRISTALLO GIREVOLI SINCRONIZZATI. BASE E SUPPORTI IN ACCIAIO VERNICIATO O GALVANIZZATO. DISPONIBILE ANCHE CON PIANI IN CERAMICA.

EXTENSIBLE COCKTAIL TABLE WITH SYNCHRONIZED REVOLVING GLASS TOPS. BASE AND SUPPORTS IN GALVANISED OR PAINTED STEEL. AVAILABE ALSO WITH CERAMICS TOPS.

TABLE DE SALON EXTENSIBLE AVEC PLATEAUX TOURNANTS SYNCRONISES EN VERRE. BASE ET SUPPORTS EN ACIER LAQUÉ OU GALVANISÉ. DISPONIBILE AUSSI AVEC PLATEAUX EN CERAMIQUE.

AUSZIEHBARER COUCHTISCH MIT SYNCHRON DREHBAHREN PLATTEN AUS KRISTALLGLAS. BASIS UND TRÄGER AUS LACKIERTEM ODER GALVANISIERTEM STAHL. LIEFERBAR AUCH MIT KERAMIKPLATTEN.

AQUILYPS *VariActions*



BASE & SUPPORTS 34 SATIN NICKEL - TOPS 08 EXTRALIGHT GLASS



BASE STONE SAVOIA ANTRACITE - SUPPORTS 34 SATIN NICKEL - TOPS STONE SAVOIA ANTRACITE / 08 EXTRALIGHT GLASS

LYPS

TAVOLINO ANGOLARE COORDINATO AL MODELLO AQUILYPS.

CORNER TABLE MATCHING WITH AQUILYPS COCKTAIL TABLE.

BOUT DE CANAPE ASSORTI À LA TABLE DE SALON AQUILYPS.

PASSENDER BEISTELLTISCH IN GLEICHEN AUSFUHRUNGEN DES AQUILYPS COUCHTISCH.



AQUÌ



CHIZINE
CHIZINE
CHIZINE

AQUÌ design A. Gamba L. Guerra

AQUÌ VariActions



BASE 66 WHITE GLASS - SUPPORTS 37 CHROME - TOPS 08 EXTRALIGHT GLASS



BASE 74 SMOKE MIRROR - SUPPORTS 37 CHROME - TOPS 08 EXTRALIGHT GLASS

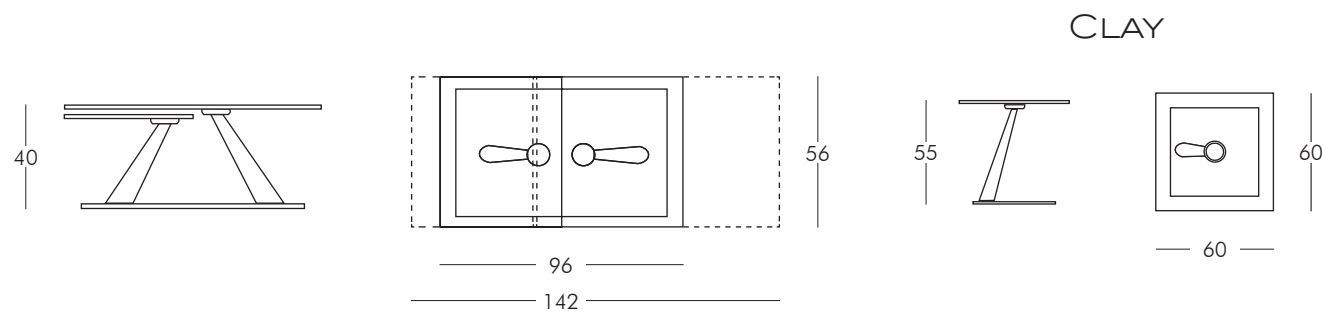

CLAY

TAVOLINO ESTENSIBILE CON PIANI IN CRISTALLO GIREVOLI SINCRONIZZATI. BASE IN CRISTALLO STRATIFICATO. SUPPORTI IN ACCIAIO VERNICIATO O GALVANIZZATO. DISPONIBILE ANCHE CON PIANI IN CERAMICA.

EXTENSIBLE COCKTAIL TABLE WITH SYNCHRONISED REVOLVING GLASS TOPS. BASE IN STRATIFIED GLASS. SUPPORTS IN PAINTED OR GALVANISED STEEL. AVAILABE ALSO WITH CERAMICS TOPS.

TABLE DE SALON EXTENSIBLE AVEC PLATEAUX TOURNANTS- SYNCHRONISÉS EN VERRE. PIÈTEMENT EN VERRE STRATIFIÉ. SUPPORTS EN ACIER LAQUÉ OU GALVANISÉ. DISPONIBILE AUSSI AVEC PLATEAUX EN CERAMIQUE.

AUSZIEHBARER COUCHTISCH MIT SYNCHRON DREHBAREN PLATTEN AUS KRISTALLGLAS. BASIS AUS SCHICHTKRISTALLGLAS. TRÄGER AUS LACKIERTEM ODER GALVANISIERTEM STAHL. LIEFERBAR AUCH MIT KERAMIKPLATTEN.

TAVOLINO ANGOLARE COORDINATO AL MODELLO AQUÌ.

CORNER TABLE MATCHING WITH AQUÌ COCKTAIL TABLE.

BOUT DE CANAPE ASSORTI À LA TABLE DE SALON AQUÌ.

PASSENDER BEISTELLTISCH IN GLEICHEN AUSFUHRUNGEN DES AQUÌ COUCHTISCH.



SAMURAI *design A. Tomaiuolo*

SAMURAI *VariActions*



BASE & SUPPORTS 31 BR BRONZO CHAMPAGNE - TOPS CAPRAIA / 00 NATURAL GLASS



BASE 11 MATT BLACK - SUPPORTS 37 CHROME - TOPS CALACATTA BLACK / 00 NATURAL GLASS

SAMURAI LAMP

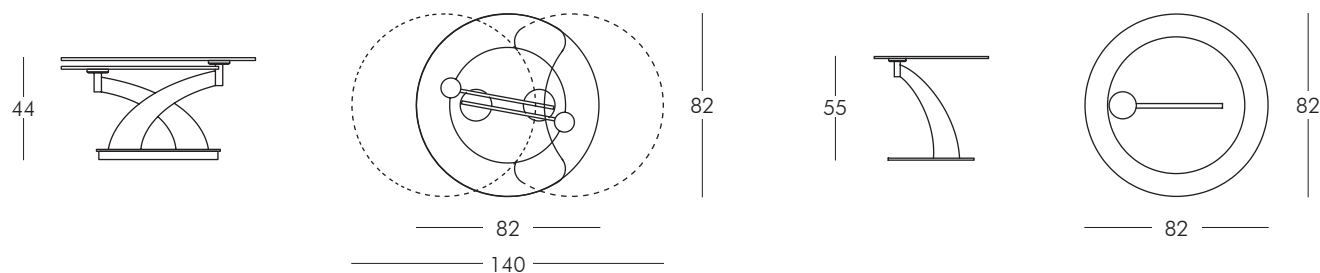

TAVOLINO ESTENSIBILE CON DUE PIANI IN CRISTALLO O CERAMICA. DOTATO DI UN MECCANISMO SINCRONIZZATO DI APERTURA CHE PERMETTE AI DUE CRISTALLI DI APRIRSI CON UN SOLO GESTO. SUPPORTI IN ACCIAIO VERNICIATO O CROMATO. BASE IN ACCIAIO VERNICIATO.

EXTENSIBLE COFFEE TABLE WITH 2 TOPS IN GLASS OR CERAMIC. EQUIPPED WITH AN EASY SYNCRONIZED OPENING MECHANISM THAT ALLOW, WITH A SIMPLE GESTURE, THE 2 TOPS TO BE OPENED. CHOME PLATED OR PAINTED STEEL SUPPORTS. BASE IN PAINTED STEEL.

TABLE BASSE EXTENSIBLE AVEC DEUX PLATEAUX EN VERRE OU EN CÉRAMIQUE. EQUIPÉ D'UN MÉCANISME D'OUVERTURE SYNCRONISÉE QUI PERMET AUX DEUX PLATEAUX DE S'OUVRIR D'UN SEUL GESTE. SUPPORTS EN MÉTAL LAQUÉ OU CHROMÉ. BASE EN MÉTAL LAQUÉ.

AUSZIEHBARER COUCHTISCH MIT ZWEI PLATTEN AUS KRISTALLGLAS ODER KERAMIK. DIESER COUCHTISCH IST MIT EINEM MECHANISMUS AUGESTATTET, WELCHER EINE SYNCHRONISIERTE ÖFFNUNG DER ZWEI PLATTEN AUF EINFACHE ART UND WEISE ERMÖGLICHT. TRÄGER AUS LACKIERTEM ODER VERCHROMTEM STAHL. SOCKEL AUS LACKIERTEM STAHL.

SAMURAI LAMP

TAVOLINO ANGOLARE COORDINATO AL MODELLO SAMURAI.

CORNER TABLE MATCHING WITH ABRA COCKTAIL SAMURAI.

BOUT DE CANAPE ASSORTI À LA TABLE DE SALON SAMURAI.

PASSENDER BEISTELLTISCH IN GLEICHEN AUSFUHRUNGEN DES SAMURAI COUCHTISCH.



HIVE



HIVE design A. Casati

HIVE VariActions



FRAME 33 NICKEL BLACK - TOP BLACK DESIRE - TOPS 08 EXTRALIGHT GLASS

DESSERT

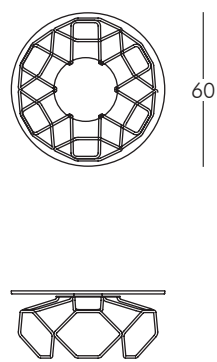

LAMP

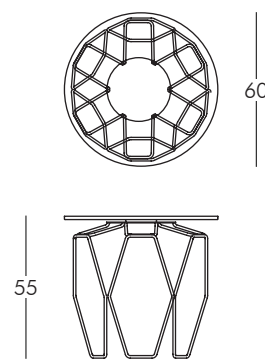

FIX TABLE

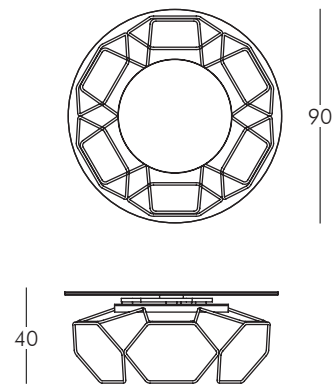

ACTION

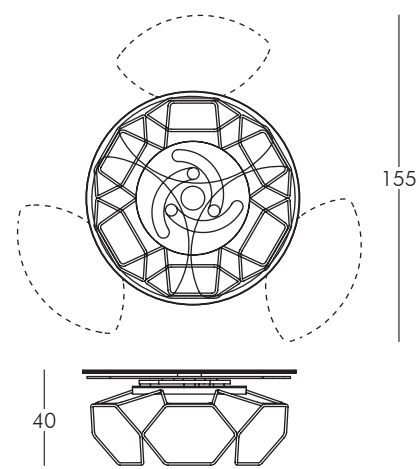

TAVOLINO ESTENSIBILE CON PIANI IN CERAMICA E CRISTALLO, BASE IN ACCIAIO VERNICIATO O GALVANIZZATO. DOTATO DI UN INNOVATIVO MECCANISMO CHE, ATTRAVERSO LA SOLA ROTAZIONE DEL PIANO SUPERIORE, PERMETTE AI TRE PIANETTI SOTTOSTANTI DI APRIRSI. DISPONIBILE ANCHE SENZA MECCANISMO.

EXTENSIBLE COCKTAIL TABLE WITH CERAMIC AND GLASS TOPS, PAINTED OR GALVANIZED STEEL BASE. EQUIPPED WITH AN INNOVATIVE MECHANISM THAT THROUGH THE UPPER ROUND TOP ROTATION, ALLOWS THE LOWEST 3 SMALL TOPS TO OPEN AUTOMATICALLY. AVAILABLE ALSO WITHOUT MECHANISM.

TABLE DE SALON AVEC PATEAUX EN CERAMIQUE ET VERRE, BASE EN ACIER. LAQUEE OU TRAITEE AU BAIN GALVANIQUE, EQUIPEE D'UN MECANISME NOVATEUR QUI, PAR LA SEULE ROTAZIONE DU PATEAU SUPERIEUR PERMET L'OUVERTURE DES 3 TABLETTES INFERIEURES. DISPONIBLE AUSSI SANS MECANISME.

AUSZIEHBARER COUCHTISCH MIT KERAMIKPLATTEN UND KRISTALLGLAS. BASIS AUS LACKIERTEM ODER GALVANISIERTEM STAHL. AUSGESTATTET MIT EINEM INNOVATIVEN MECHANISMUS, DIE DURCH EINE DREHUNG DER OBENPLATTE ES ERMÖGLICHT DIE 3 UNTERE REGALE ZU ÖFFNEN. VERFÜGBAR AUCH IN DER FEST VERSION.



FRAME 370 GOLD SHINY - TOP STONE SAVOIA PERLA - TOPS 08 EXTRALIGHT GLASS

LES JEUX SONT FAITS



LES JEUX SONT FAITS *design A. Casati*

LES JEUX SONT FAITS *VariActions*



FIX COFFEE TABLE - FRAME 370 GOLD SHINY - TOP STATUARIO



FRAME 33 NICKEL BLACK - TOP STONE SAVOIA ANTRACITE - TOPS 00 NATURAL GLASS



FRAME 370 GOLD SHINY - TOP BLACK DESIRE - TOPS 00 NATURAL GLASS

FIX TABLE

ACTION

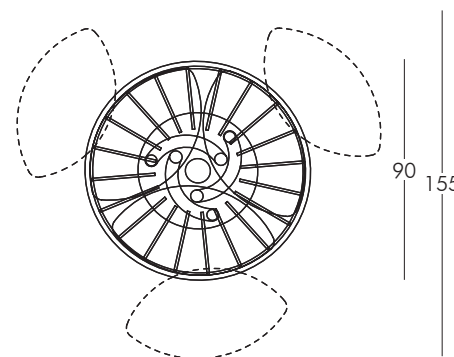
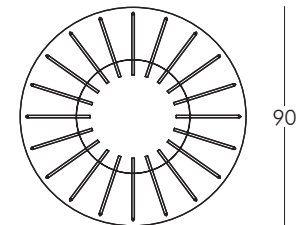
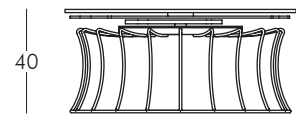

TAVOLINO ESTENSIBILE CON PIANI IN CERAMICA E CRISTALLO, BASE IN ACCIAIO VERNICIATO O GALVANIZZATO. DOTATO DI UN INNOVATIVO MECCANISMO CHE, ATTRAVERSO LA SOLA ROTAZIONE DEL PIANO SUPERIORE, PERMETTE AI TRE PIANETTI SOTTOSTANTI DI APRIRSI. DISPONIBILE ANCHE SENZA MECCANISMO.

EXTENSIBLE COCKTAIL TABLE WITH CERAMIC AND GLASS TOPS, PAINTED OR GALVANIZED STEEL BASE. EQUIPPED WITH AN INNOVATIVE MECHANISM THAT THROUGH THE UPPER ROUND TOP ROTATION, ALLOWS THE LOWEST 3 SMALL TOPS TO OPEN AUTOMATICALLY. AVAILABLE ALSO WITHOUT MECHANISM.

TABLE DE SALON AVEC PATEAUX EN CERAMIQUE ET VERRE, BASE EN ACIER. LAQUEE OU TRAITEE AU BAIN GALVANIQUE, EQUIPEE D'UN MECANISME NOVATEUR QUI, PAR LA SEULE ROTAZION DU PATEAU SUPERIEUR PERMET L'OUVERTURE DES 3 TABLETTES INFERIEURES. DISPONIBLE AUSSI SANS MECANISME.

AUSZIEHBARER COUCHTISCH MIT KERAMIKPLATTEN UND KRISTALLGLAS. BASIS AUS LACKIERTEM ODER GALVANISIERTEM STAHL. AUSGESTATTET MIT EINEM INNOVATIVEN MECHANISMUS, DIE DURCH EINE DREHUNG DER OBERPLATTE ES ERMÖGLICHT DIE 3 UNTERE REGALE ZU ÖFFNEN. VERFÜGBAR AUCH IN DER FEST VERSION.

MAGELLANO



MAGELLANO *design A. Casati*

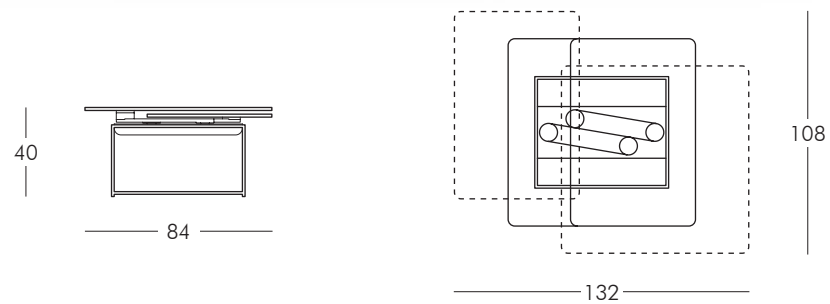

TAVOLINO ESTENSIBILE CON PIANI IN CERAMICA, BASE IN ACCIAIO VERNICIATO O GALVANIZZATO. DOTATO DI UN INNOVATIVO MECCANISMO CHE PERMETTE AI DUE PIANI DI APRIRSI.

EXTENSIBLE COCKTAIL TABLE WITH CERAMIC TOPS, PAINTED OR GALVANIZED STEEL BASE. EQUIPPED WITH AN INNOVATIVE MECHANISM THAT ALLOWS THE LOWEST 2 SMALL TOPS TO OPEN AUTOMATICALLY.

TABLE DE SALON AVEC PLATEAUX EN CERAMIQUE. BASE EN ACIER LAQUEE OU TRAITEE AU BAIN GALVANIQUE, EQUIPEE D'UN MECANISME NOUVEAU QUI PERMET L'OUVERTURE DES 2 TABLETTES.

AUSZIEHBARER COUCHTISCH MIT KERAMIKPLATTEN. BASIS AUS LACKIERTEM ODER GALVANISIERTEM STAHL. AUSGESTATTET MIT EINEM INNOVATIVEN MECHANISMUS, DIE ERMÖGLICHT DIE 2 UNTERE REGALE ZU ÖFFNEN.

MAGELLANO *VariActions*



FRAME 111 MATT BLACK - TOPS ARABESCATO



FRAME 670 COPPER - TOPS STONE SAVOIA PERLA



FRAME 570 SMOKE - TOPS BLACK DESIRE

AMERIGO



AMERIGO *design A. Casati*

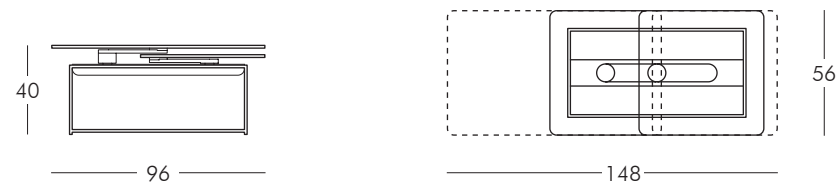

TAVOLINO ESTENSIBILE CON PIANI IN CERAMICA, BASE IN ACCIAIO VERNICIATO O GALVANIZZATO. DOTATO DI UN INNOVATIVO MECCANISMO CHE PERMETTE AI DUE PIANI DI APRIRSI.

EXTENSIBLE COCKTAIL TABLE WITH CERAMIC TOP, PAINTED OR GALVANIZED STEEL BASE. EQUIPPED WITH AN INNOVATIVE MECHANISM THAT ALLOWS THE LOWEST 2 SMALL TOPS TO OPEN AUTOMATICALLY.

TABLE DE SALON AVEC PLATEAUX EN CERAMIQUE. BASE EN ACIER LAQUEE OU TRAITEE AU BAIN GALVANIQUE, EQUIPEE D'UN MECANISME INNOVATEUR QUI PERMET L'OUVERTURE DES 2 TABLETTES.

AUSZIEHBARER COUCHTISCH MIT KERAMIKPLATTEN. BASIS AUS LACKIERTEM ODER GALVANISIERTEM STAHL. AUSGESTATTET MIT EINEM INNOVATIVEN MECHANISMUS, DIE ERMÖGLICHT DIE 2 UNTERE REGALE ZU ÖFFNEN.

AMERIGO *VariActions*



FRAME 7044 SAND - TOPS STONE SAVOIA PERLA



FRAME 370 GOLD SHINY - TOPS BLACK DESIRE



FRAME 570 SMOKE - TOPS SAHARA NOIR

COLOMBO



COLOMBO *design Naos*

COLOMBO *VariActions*



FRAME 33 BLACK NIKEL - TOPS GOLD MARBLE



FRAME 670 COPPER - TOPS STONE SAVOIA ANTRACITE



FRAME 370 CROME - TOPS BLACK DESIRE

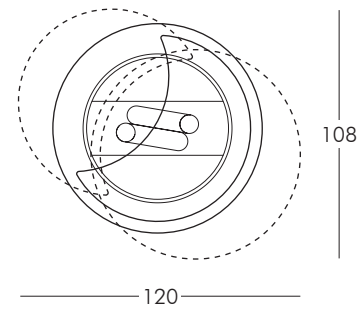
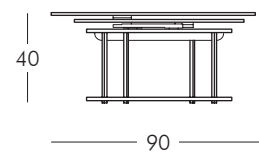

TAVOLINO ESTENSIBILE CON PIANI IN CERAMICA, BASE IN ACCIAIO VERNICIATO O GALVANIZZATO. DOTATO DI UN INNOVATIVO MECCANISMO CHE PERMETTE AI DUE PIANI DI APRIRSI.

EXTENSIBLE COCKTAIL TABLE WITH CERAMIC TOP, PAINTED OR GALVANIZED STEEL BASE. EQUIPPED WITH AN INNOVATIVE MECHANISM THAT ALLOWS THE LOWEST 2 SMALL TOPS TO OPEN AUTOMATICALLY.

TABLE DE SALON AVEC PLATEAUX EN CERAMIQUE. BASE EN ACIER LAQUEE OU TRAITEE AU BAIN GALVANIQUE, EQUIPEE D'UN MECANISME NOVATEUR QUI PERMET L'OUVERTURE DES 2 TABLETTES.

AUSZIEHBARER COUCHTISCH MIT KERAMIKPLATTEN. BASIS AUS LACKIERTEM ODER GALVANISIERTEM STAHL. AUSGESTATTET MIT EINEM INNOVATIVEN MECHANISMUS, DIE ERMÖGLICHT DIE 2 UNTERE REGALE ZU ÖFFNEN.

UPTOWN

*SUSPENDED
MUSE*





UPTOWN *design A. Casati*

UPTOWN *VariActions*



FIX TABLE

ACTION

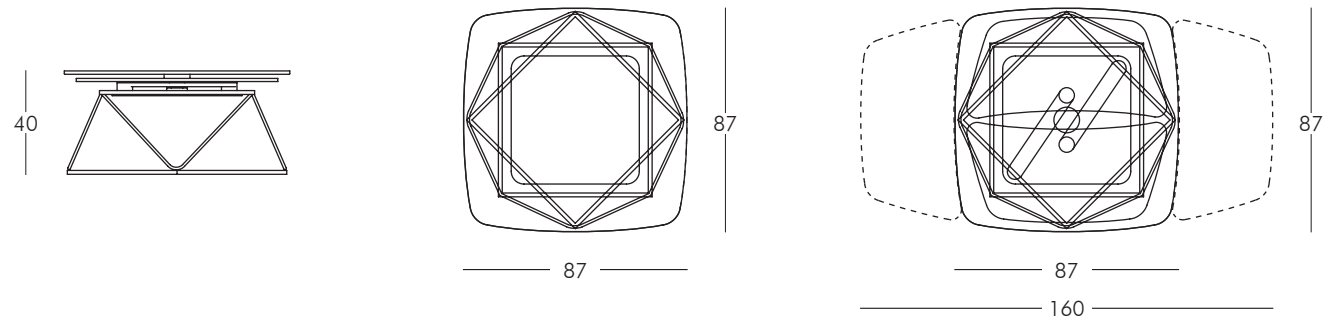

TAVOLINO ESTENSIBILE CON PIANI IN CERAMICA E CRISTALLO, BASE IN ACCIAIO VERNICIATO O GALVANIZZATO. DOTATO DI UN INNOVATIVO MECCANISMO CHE, ATTRAVERSO LA SOLA ROTAZIONE DEL PIANO SUPERIORE, PERMETTE AI DUE PIANETTI SOTTOSTANTI DI APRIRSI. DISPONIBILE ANCHE SENZA MECCANISMO.

EXTENSIBLE COCKTAIL TABLE WITH CERAMIC AND GLASS TOPS, PAINTED OR GALVANIZED STEEL BASE. EQUIPPED WITH AN INNOVATIVE MECHANISM THAT THROUGH THE UPPER ROUND TOP ROTATION, ALLOWS THE LOWEST 2 SMALL TOPS TO OPEN AUTOMATICALLY. AVAILABLE ALSO WITHOUT MECHANISM.

TABLE DE SALON AVEC PATEAUX EN CERAMIQUE ET VERRE, BASE EN ACIER LAQUEE OU TRAITEE AU BAIN GALVANIQUE, EQUIPEE D'UN MECANISME NOVATEUR QUI, PAR LA SEULE ROTATION DU PATEAU SUPERIEUR PERMET L'OUVERTURE DES 2 TABLETTES INFERIEURES. DISPONIBLE AUSSI SANS MECANISME.

AUSZIEHBARER COUCHTISCH MIT KERAMIKPLATTEN UND KRISTALLGLAS. BASIS AUS LACKIERTEM ODER GALVANISIERTEM STAHL. AUSGESTATTET MIT EINEM INNOVATIVEN MECHANISMUS, DIE DURCH EINE DREHUNG DER OBERPLATTE ES ERMÖGLICHT DIE 2 UNTERE REGALE ZU ÖFFNEN. VERFÜGBAR AUCH IN DER FEST VERSION.



FIX COFFEE TABLE - FRAME 33 NICKEL BLACK - TOP BLACK DESIRE



FRAME 670 COPPER - TOP BLACK STONE - TOPS 08 EXTRALIGHT GLASS



FRAME 7016 MATT ANTRACITE - TOP INVISIBLE WHITE - TOPS 08 EXTRALIGHT GLASS

BASALTO

*SEDUCTIVE
INSPIRATION*





BASALTO *design A. Casati*

BASALTO *VariActions*



BASE STONE SAVOIA PERLA - SUPPORTS 37 CHROME - TOPS STONE SAVOIA PERLA



BASE BLACK DESIRE - SUPPORTS 370 GOLD SHINY - TOPS BLACK DESIRE

BASALTO LAMP

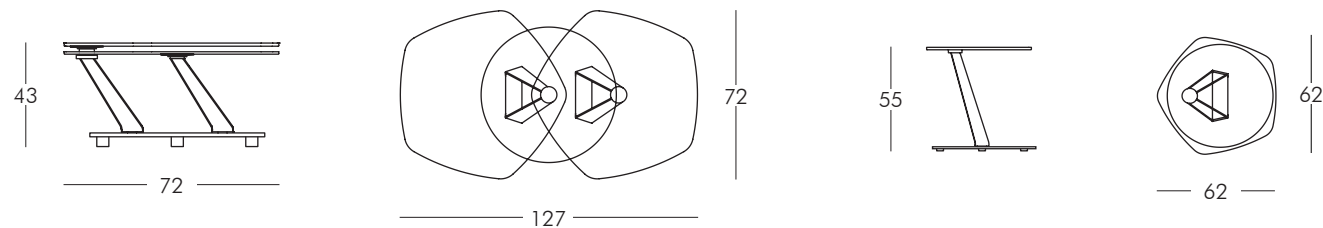

TAVOLINO ESTENSIBILE CON PIANI GIREVOLI SINCRONIZZATI DISPONIBILI IN VETRO O CERAMICA. BASE IN CERAMICA O IN FINITURE VERNICIATE. SUPPORTI VERNICIATI O CROMATI. LA BASE È DOTATA DI UN MECCANISMO DI ROTAZIONE SINCRONIZZATO, CHE CONSENTE UN'AMPIA MODULAZIONE DELLA FORMA.

EXTENSIBLE COCKTAIL TABLE WITH SYNCHRONIZED REVOLVING TOPS IN GLASS OR CERAMIC SELECTIONS. BASE IN CERAMIC OR IN PAINTED FINISHINGS. SUPPORTS IN PAINTED FINISHINGS OR GALVANIZED STEEL. THE BASE IS EQUIPPED WITH A MECHANISM FOR THE SYNCHRONIZED ROTATION OF THE TOPS THAT ALLOW AMPLE MODULATION OF THE SHAPE.

TABLE DE SALON AVEC PLATEAUX DISPONIBLES DANS TOUTES LES FINITIONS CÉRAMIQUE OU EN VERRE. BASE EN CERAMIQUE OU LAQUÉE. SUPPORTS EN ACIER LAQUÉ OU GALVANISÉ. LA BASE EST EQUIPÉE D'UN MÉCANISME DE ROTATION SYNCHRONISÉE QUI PERMET UNE GRANDE VARIÉTÉ DE POSITIONS.

AUSZIEHBARER COUCHTISCH MIT KERAMIKPLATTEN UND KRISTALLGLAS. UNTERGESTELL AUS KERAMIK ODER IN LACKIERTER AUSFÜHRUNG. TRÄGER AUS LACKIERTEM ODER GALVANISIERTEM STAHL. DER BESONDERE MECHANISMUS ERLAUBT ES DEN PLATTEN VIELFALTIGE POSIZIEN EINZUNEHMEN.

BASALTO LAMP

TAVOLINO ANGOLARE COORDINATO AL MODELLO BASALTO.

CORNER TABLE MATCHING WITH BASALTO COCKTAIL TABLE.

BOUT DE CANAPE ASSORTI À LA TABLE DE SALON BASALTO.

PASSENDER BEISTELLTISCH IN GLEICHEN AUSFÜHRUNGEN DES BASALTO COUCHTISCH.



DISCOVERY



DISCOVERY *design A. Casati*

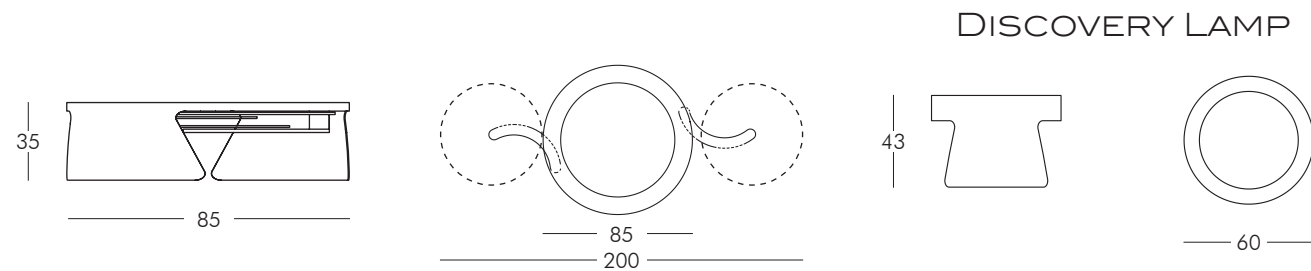

DISCOVERY LAMP

TAVOLINO ESTENSIBILE CON PIANI IN CERAMICA O CRISTALLO. STRUTTURA DISPONIBILE NELLE FINITURE VERNICIATE. PIANO SUPERIORE IN CERAMICA, PIANI INFERIORI DISPONIBILI IN CRISTALLO O CERAMICA, DOTATO DI UN INNOVATIVO MECCANISMO CHE ATTRAVERSO LA ROTAZIONE DEL PIANO TONDO SUPERIORE, PERMETTE L'APERTURA AUTOMATICA DEI 2 PIANI INFERIORI.

EXTENSIBLE COCKTAIL TABLE WITH CERAMIC STONE AND PORCELAIN SELECTIONS OR GLASS TOP. FRAME AVAILABLE IN PAINTED FINISHINGS. ROUND TOP IN CERAMIC STONE AND PORCELAIN SELECTIONS, LOWER SMALL TOPS AVAILABLE IN GLASS OR IN CERAMIC STONE AND PORCELAIN. EQUIPPED WITH AN INNOVATIVE MECHANISM THAT THROUGH THE UPPER ROUND TOP ROTATION, ALLOWS THE LOWEST 2 SMALL TOPS TO OPEN AUTOMATICALLY.

TABLE DE SALON EXTENSIBLE AVEC PLATEAUX DISPONIBLES DANS TOUTES LES FINITIONS CÉRAMIQUE OU EN VERRE. STRUCTURE DISPONIBLE EN FINITION LAQUÉE. PLATEAU ROND EN CÉRAMIQUE, PLATEAUX INFÉRIEURS DISPONIBLES EN VERRE OU EN CÉRAMIQUE. EQUIPÉE D'UN MÉCANISME INOYANT QUI, PAR LA SEULE ROTAZIONE DU PLATEAU SUPÉRIEUR PERMET L'OUVERTURE DES 2 TABLETTES INFÉRIEURES AUTOMATIQUEMENT.

AUSZIEHBARER COUCHTISCH MIT KERAMIKPLATTEN UND KRISTALLGLAS. GESTLL IN LACKIERTEN AUSFUEHRUNGEN. RUNDE PLATTE IN KERAMIK; DIE UNTEREN PLATTEN AUS KERAMIK ODER AUS KRISTALLGLAS. AUSGESTATTET MIT EINEM INNOVATIVEN MECHANISMUS, DER ES DURCH EINE DREHHUNG DER OBENPLATTE ERMOGLICHT DIE 2 UNTEREN REGALE ZU OEFFNEN.

DISCOVERY *VariActions*



FRAME 10 MATT WHITE - TOP STONE FOKOS SALE - TOPS 08 EXTRALIGHT GLASS



FRAME 11 MATT BLACK - TOP BLACK DESIRE - TOPS 74 SMOKE FUMÈ

DISCOVERY LAMP

TAVOLINO ANGOLARE COORDINATO AL MODELLO DISCOVERY.

CORNER TABLE MATCHING WITH DISCOVERY COCKTAIL TABLE.

BOUT DE CANAPE ASSORTI À LA TABLE DE SALON DISCOVERY.

PASSENDER BEISTELLTISCH IN GLEICHEN AUSFUHRUNGEN DES DISCOVERY COUCHTISCH.



GIROTONDO



GIROTONDO *design A. Tomaiuolo*

TAVOLINO ESTENSIBILE CON PIANI GIREVOLI SINCRONIZZATI. BASE IN ACCIAIO VERNICIATO. PIANO SUPERIORE IN CERAMICA E PIANO INFERIORE IN CRISTALLO O CERAMICA.

EXTENSIBLE COFFE TABLE WITH SYNCHRONISED REVOLVING TOP GLASS TOPS. BASE IN PAINTED STEEL. UPPER TOP IN CERAMIC AND LOWEST TOP IN GLASS OR CERAMIC.

TABLE DE SALON EXTENSIBLE AVEC PLATEAUX TOURNANTS EN SYNCHRONIE. SOCLE EN ACIER LAQUE, PLATEAU SUPERIEUR EN CERAMIQUE, INFERIEUR EN VERRE OU CERAMIQUE.

AUSZIEHBARER COUCHTISCH MIT SYNCHRONISIERTEN DREHBAREN PLATTEN. UNTERGESTELL AUS LACKIERTEM STAHL. OBERPLATTE AUS KERAMIK UND UNTERPLATTE AUS GLAS ODER KERAMIK.

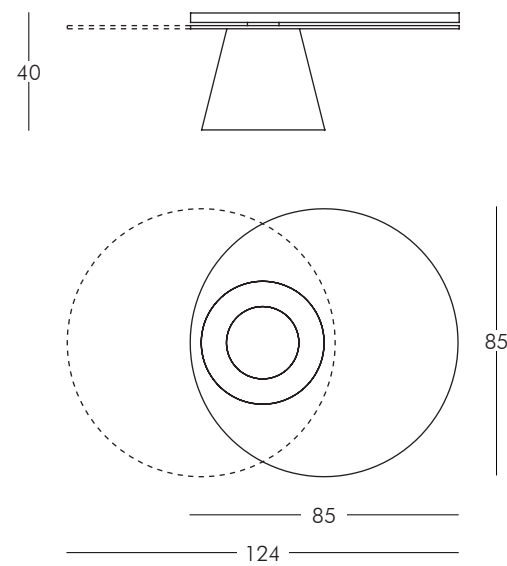

BATIS



BATIS *design A. Casati*

TAVOLINO ESTENSIBILE CON 3 PIANI IN CRISTALLO O CERAMICA. DOTATO DI UN INNOVATIVO DOPPIO MECCANISMO SINCRONIZZATO DI APERTURA CHE PERMETTE AI 3 CRISTALLI DI APRIRSI CON UN SOLO GESTO MA IN DIREZIONI OPPOSITE. SUPPORTI IN ACCIAIO VERNICIATO O CROMATO.

EXTENSIBLE COFFEE TABLE WITH 3 GLASS OR CERAMIC TOPS. EQUIPPED WITH AN INNOVATIVE DOUBLE SYNCHRONIZED MECHANISM THAT ALLOW THE 3 TOPS TO BE OPENED AT ONCE, WITH A SIMPLE GESTURE AND BE AT THE SAME TIME PLACED IN DIFFERENT DIRECTIONS. SUPPORTS IN PAINTED OR CHROMED STEEL.

TABLE DE SALON EXTENSIBLE AVEC 3 PLATEAUX EN VERRE OU CERAMIQUE. EQUIPÉE D'UN MÉCANISME SYNCHRONISÉ À DOUBLE EFFET, QUI PERMET L'OUVERTURE SIMULTANÉE DES 3 PLATEAUX, MAIS EN DIRECTIONS OPPOSÉES. SUPPORTS EN ACIER LAQUÉ OU CHROMÉ.

AUSZIEHBARER COUCHTISCH MIT 3 PLATTEN AUS KRISTALLGLAS ODER KERAMIK. AUSGESTATTET MIT EINER INNOVATIVEN SYNCHRONISIERTEN DOPPELMECHANISMUS, DIE MIT EINER EINZIGEN BEWEGUNG DIE 3 GLASPLATTEN ERLAUBT SICH ZU ÖFFNEN, ABER IN GEGENSÄTZLICHEN RICHTUNGEN. TRÄGER AUS VERCHROMTEM ODER LACKIERTEM STAHL.

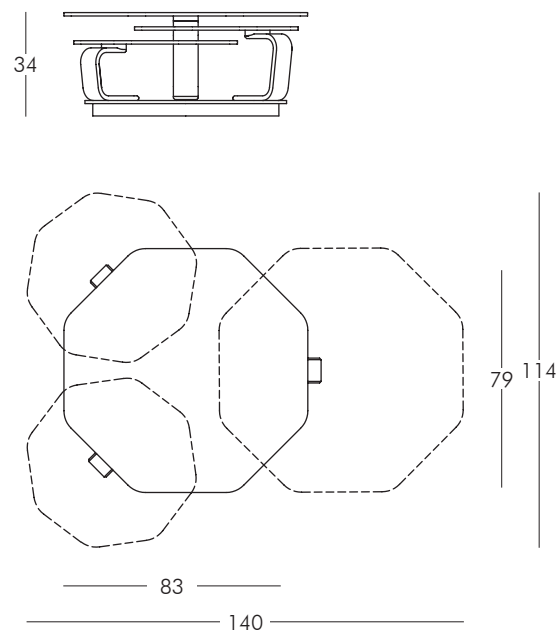

BLOSSOM design A. Casati

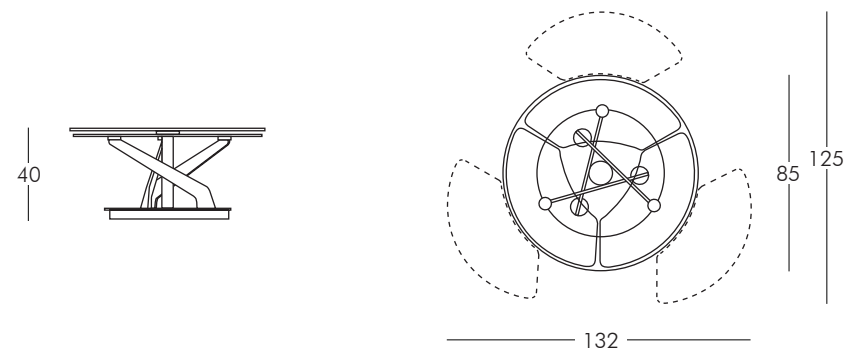

TAVOLINO ESTENSIBILE DOTATO DI UN INNOVATIVO MECCANISMO CHE, ATTRAVERSO LA SOLA ROTAZIONE A 360° DEL PIANO SUPERIORE, PERMETTE AI TRE PIANETTI SOTTOSTANTI DI APRIRSI. IN POSIZIONE CHIUSA IL PIANO SUPERIORE NASCONDE I PIANI SOTTOSTANTI.

EXTENSIBLE COFFEE TABLE EQUIPPED WITH AN INNOVATIVE MECHANISM THAT THROUGH THE UPPER ROUND TOP 360° ROTATION, ALLOWS THE LOWEST 3 SMALL TOPS TO OPEN AUTOMATICALLY. IN CLOSED POSITION THE LOWEST SMALL TOPS ARE HIDDEN BY THE ROUND UPPER TOP.

TABLE DE SALON EXTENSIBLE EQUIPEE D'UN MECANISME NOVATEUR QUI, PAR LA SEULE ROTAZION A 360° DU PLATEAU SUPERIEUR PERMET L'OUVERTURE DES 3 TABLETTES INFERIEURES, EN POSITION FERMEE LE PLATEAU SUPERIEUR CACHE LES 3 INFERIEURS.

AUSZIEHBARER COUCHTISCH AUSGESTATTET MIT EINEM INNOVATIVEN MECHANISMUS, DIE DURCH EINE 360° DREHUNG DER OBERPLATTE ES ERMÖGLICHT DIE 3 UNTERE REGALE ZU ÖFFNEN. IN DER GESCHLOSSENE POSITION VERSTECKT DIE OBERPLATTE DIE 3 UNTERE REGALE.



PETRES *design A. Casati*

TAVOLINO ESTENSIBILE DOTATO DI UN INNOVATIVO MECCANISMO CHE, ATTRAVERSO LA SOLA ROTAZIONE DEL PIANO SUPERIORE, PERMETTE AI TRE PIANETTI SOTTOSTANTI DI APRIRSI. IN POSIZIONE CHIUSA IL PIANO SUPERIORE NASCONDE I PIANI SOTTOSTANTI.

EXTENSIBLE COFFEE TABLE EQUIPPED WITH AN INNOVATIVE MECHANISM THAT THROUGH THE UPPER ROUND TOP 360° ROTATION, ALLOWS THE LOWEST 3 SMALL TOPS TO OPEN AUTOMATICALLY. IN CLOSED POSITION THE LOWEST SMALL TOPS ARE HIDDEN BY THE ROUND UPPER TOP.

TABLE DE SALON EXTENSIBLE EQUIPEE D'UN MECANISME NOVATEUR QUI, PAR LA SEULE ROTATION A 360° DU PLATEAU SUPERIEUR PERMET L'OUVERTURE DES 3 TABLETTES INFERIEURES, EN POSITION FERMEE LE PLATEAU SUPERIEUR CACHE LES 3 INFERIEURS.

AUSZIEHBARER COUCHTISCH AUSGESTATTET MIT EINEM INNOVATIVEN MECHANISMUS, DIE DURCH EINE 360° DREHUNG DER OBENPLATTE ES ERMÖGLICHT DIE 3 UNTERE REGALE ZU ÖFFNEN. IN DER GESCHLOSSENE POSITION VERSTECKT DIE OBENPLATTE DIE 3 UNTERE REGALE.

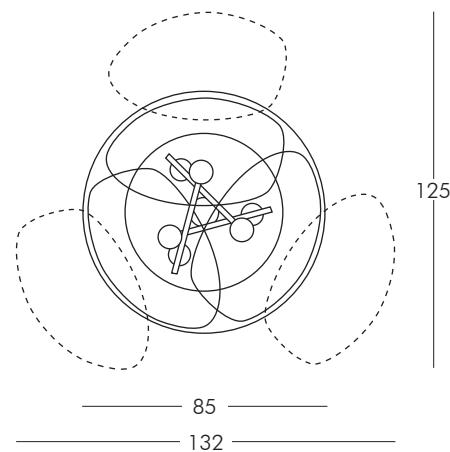
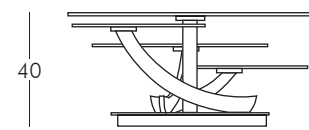

AVIOR *design A. Casati*

AVIOR *VariActions*



FRAME 10 MATTE WHITE - TOPS CALACATTA / 00 NATURAL GLASS



FRAME 5310 TAUPE - TOPS CAPRAIA / 00 NATURAL GLASS



FRAME 2525 MANGANESE - TOPS STONE TRAVERTINO

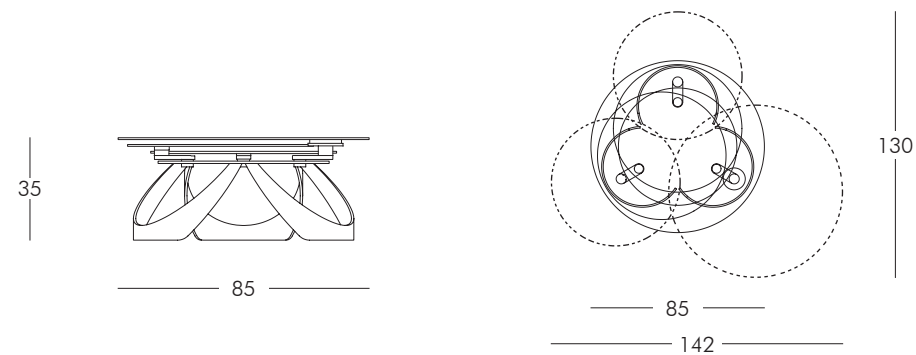

TAVOLINO ESTENSIBILE CON 3 PIANI IN CRISTALLO O CERAMICA. DOTATO DI UN DOPPIO MECCANISMO SINCRONIZZATO DI APERTURA CHE PERMETTE AI 3 CRISTALLI DI APRIRSI CON UN SOLO GESTO MA IN DIREZIONI OPPOSITE. STRUTTURA IN ACCIAIO VERNICIATO.

EXTENSIBLE COFFEE TABLE WITH 3 TOPS IN GLASS OR CERAMIC. EQUIPPED WITH AN EASY SYNCRONIZED OPENING MECHANISM THAT ALLOW, WITH A SIMPLE GESTURE, THE 3 TOPS TO BE OPENED AT ONCE AND TO BE AT THE SAME TIME PLACED IN DIFFERENT DIRECTIONS. FRAME IN PAINTED STEEL.

TABLE BASSE EXTENSIBLE AVEC 3 PLATEAUX EN VERRE OU EN CÉRAMIQUE. EQUIPÉ D'UN MÉCANISME D'OUVERTURE SYNCRONISÉE QUI PERMET AUX 3 PLATEAUX DE S'OUVRIR D'UN SEUL GESTE MAIS EN DIRECTION OPPOSÉE. STRUCTURE EN MÉTAL LAQUÉ.

AUSZIEHBARER COUFTISCH MIT DREI PLATTEN AUS KRISTALLGLAS ODER KERAMIK. DIESER COUCHTISCH IST MIT EINEM MECHANISMUS AUGESTATTET, WELCHER EINE SYNCHRONISIERTE ÖFFNUNG DER DREI PLATTEN IN GEGENSÄTZLICHEN RICHTUNGEN AUF EINFACHE ART UND WEISE ERMÖGLICHT. GESTELL AUS LACKIERTEM STAHL.

MILES *design A. Gamba L. Guerra*

MILES *VariActions*

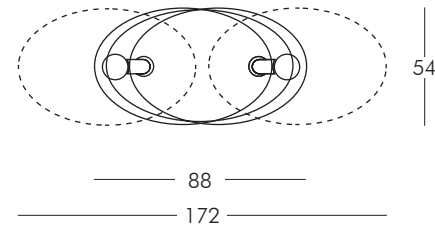
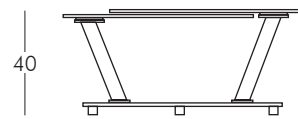

TAVOLINO ESTENSIBILE CON PIANI GIREVOLI SINCRONIZZATI IN CRISTALLO. SUPPORTI IN ACCIAIO VERNICIATO O GALVANIZZATO. LA BASE IN CRISTALLO STRATIFICATO E' DOTATA DI UN MECCANISMO PER LA ROTAZIONE SINCRONIZZATA, CHE CONSENTE UN'AMPIA MODULAZIONE DELLA POSIZIONE DEI CRISTALLI.

EXTENSIBLE COFFEE TABLE WITH SYNCHRONIZED REVOLVING CRYSTAL TOPS. SUPPORTS IN PAINTED OR GALVANIZED STEEL. THE BASE CAN BE IN STRATIFIED GLASS AND IT IS EQUIPPED WITH A MECHANISM FOR SYNCHRONIZED ROTATION OF THE TOPS THAT ALLOWS AN AMPLE MODULATION OF THE FORM.

TABLE DE SALON EXTENSIBLE AVEC PLATEAUX TOURNANTS SYNCHRONISÉS EN VERRE. SUPPORTS EN ACIER LAQUÉ OU GALVANISÉ. LA BASE EN VERRE STRATIFIÉ, EST ÉQUIPÉE D'UN MÉCANISME DE ROTATION SYNCHRONISÉE QUI PERMET UNE AMPLE MODULATION DE LA FORME.

AUSZIEHBARER COUCHTISCH MIT SYNCHRON DREHBAREN PLATTEN AUS KRISTALLGLAS. BASIS AUS SCHICHTKRISTALLGLAS. TRÄGER AUS LACKIERTEM ODER GALVANISIERTEM STAHL. DER BESONDERE MECHANISMUS ERLAUBT ES DEN PLATTEN VIELFÄLTIGE POSITIONEN EINZUNEHMEN.



BASE 66 WHITE GLASS - SUPPORTS 37 CHROME - TOPS CALACATTA / 08 EXTRALIGHT GLASS



BASE 65 BLACK MIRROR - SUPPORTS 33 NIKEL BLACK - TOPS 08 EXTRALIGHT GLASS



BASE BLACK DESIRE - SUPPORTS 370 GOLD SHINY - TOPS BLACK DESIRE / 08 EXTRALIGHT GLASS

GEMELLI design D. D'Urbino P. Lomazzi

GEMELLI VariActions



BASE 10 WHITE - SUPPORTS 37 CHROME - TOPS CALACATTA / 08 EXTRALIGHT GLASS



BASE 21 BLACK EMBOSSED - SUPPORTS 37 CHROME - TOPS STONE BLACK STONE / 08 EXTRALIGHT GLASS

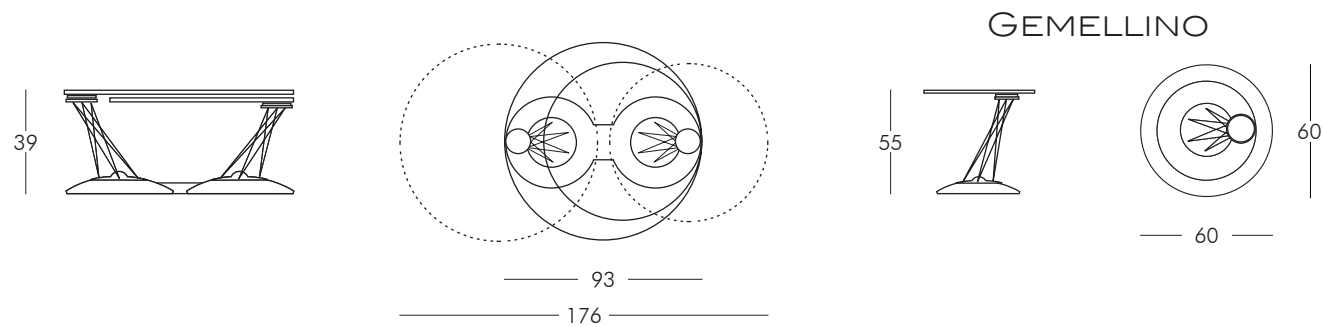

TAVOLINO ESTENSIBILE CON PIANI GIREVOLI SINCRONIZZATI IN CRISTALLO. BASE IN ACCIAIO RIVESTITA DI MATERIALE SINTETICO VERNICIATO. SUPPORTI IN ACCIAIO GALVANIZZATO.

EXTENSIBLE COCKTAIL TABLE WITH REVOLVING GLASS TOPS. BASE IN STEEL COVERED WITH SYNTHETIC PAINTED MATERIAL. SUPPORTS IN GALVANISED STEEL.

TABLE DE SALON EXTENSIBLE AVEC PLATEAUX TOURNANTS- SYNCHRONISÉS EN VERRE. BASE EN ACIER RECOUVERTE DE LAQUE SYNTHÉTIQUE. SUPPORTS EN ACIER GALVANISÉ.

AUSZIEHBARER COUCHTISCH MIT SYNCHRON DREHBAREN KRISTALLGLASPLATTEN. BASIS AUS STAHL MIT SYNTHETISCH LACKIERTEM MATERIAL UMMANTELT. TRÄGER AUS GALVANISIERTEM STAHL.

GEMELLINO

TAVOLINO ANGOLARE COORDINATO AL MODELLO GEMELLI.

CORNER TABLE MATCHING WITH GEMELLI COCKTAIL TABLE.

BOUT DE CANAPE ASSORTI À LA TABLE DE SALON GEMELLI.

PASSENDER BEISTELLTISCH IN GLEICHEN AUSFUHRUNGEN DES GEMELLI COUCHTISCH.



EXTREMIS



EXTREMIS *design A. Casati*

EXTREMIS *VariActions*



BASE & SUPPORTS 11 MATT BLACK - TOPS BLACK DESIRE



BASE & SUPPORTS 5270 DARK BROWN - TOPS DIAMOND CREAM



BASE & SUPPORTS 31BR BRONZO CHAMPAGNE - TOPS CALACATTA

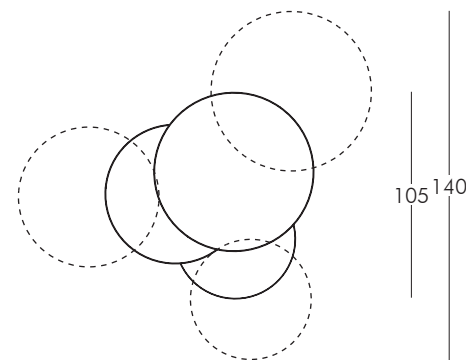
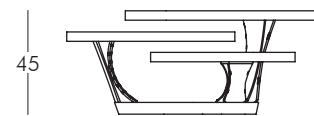

TAVOLINO ESTENSIBILE CON 3 PIANI IN CERAMICA. DOTATO DI UN INNOVATIVO MECCANISMO SINCRONIZZATO DI APERTURA CHE PERMETTE AI 3 CRISTALLI DI APRIRSI CON UN SOLO GESTO. SUPPORTI IN ACCIAIO VERNICIATO.

EXTENSIBLE COFFEE TABLE WITH 3 CERAMIC TOPS. EQUIPPED WITH AN INNOVATIVE SYNCHRONIZED MECHANISM THAT ALLOW THE 3 TOPS TO BE OPENED AT ONCE, WITH A SIMPLE GESTURE AND BE AT THE SAME TIME PLACED IN DIFFERENT DIRECTIONS. SUPPORTS IN PAINTED STEEL.

TABLE DE SALON EXTENSIBLE AVEC 3 PLATEAUX EN CERAMIQUE. EQUIPÉE D'UN MÉCANISME SYNCHRONISÉ QUI PERMET L'OUVERTURE SIMULTANÉE DES 3 PLATEAUX, SUPPORTS EN ACIER LAQUÉ.

AUSZIEHBARER COUCHTISCH MIT 3 PLATTEN AUS KERAMIK. AUSGESTATTET MIT EINER INNOVATIVEN SYNCHRONISIERTEN MECHANISMUS, DIE MIT EINER EINZIGEN BEWEGUNG DIE 3 GLASPLATTEN ERLAUBT SICH ZU ÖFFNEN, TRÄGER AUS LACKIERTEM STAHL.

ANELLI *design Y. Hatano*

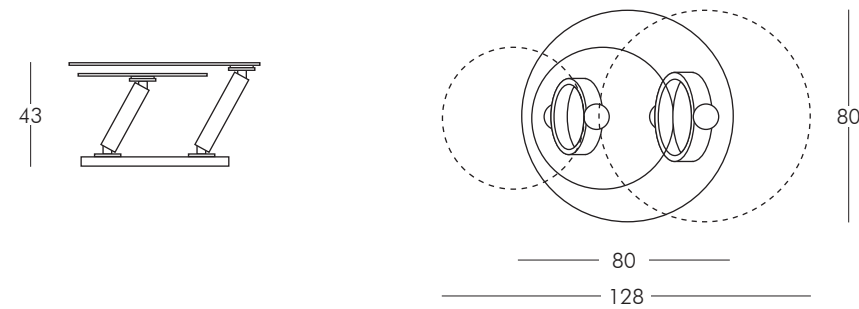

TAVOLINO ESTENSIBILE CON PIANI GIREVOLI SINCRONIZZATI IN CRISTALLO BASE IN LEGNO E SUPPORTI IN ACCIAIO VERNICIATO O GALVANIZZATO.

EXTENSIBLE COCKTAIL TABLE WITH SYNCHRONISED REVOLVING GLASS TOPS. WOODEN BASE AND SUPPORTS IN PAINTED OR GALVANISED STEEL.

TABLE DE SALON EXTENSIBLE AVEC PLATEAUX TOURNANTS- SYNCHRONISÉS EN VERRE. PIÈTEMENT EN BOIS, SUPPORTS EN ACIER LAQUÉ OU GALVANISÉ.

AUSZIEHBARER COUCHTISCH MIT SYNCHRON DREHBAREN KRISTALLGLASPLATTEN. BASIS AUS HOLZ, TRÄGER AUS LACKIERTEM ODER GALVANISIERTEM STAHL.

DONELLI *design Y. Hatano*

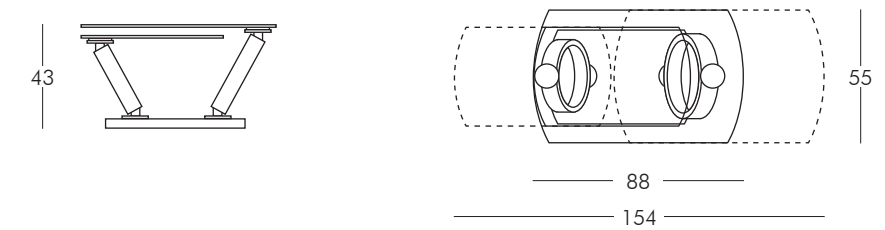

TAVOLINO ESTENSIBILE CON PIANI GIREVOLI SINCRONIZZATI IN CRISTALLO BASE IN LEGNO E SUPPORTI IN ACCIAIO VERNICIATO O GALVANIZZATO.

EXTENSIBLE COCKTAIL TABLE WITH SYNCHRONISED REVOLVING GLASS TOPS. WOODEN BASE AND SUPPORTS IN PAINTED OR GALVANISED STEEL.

TABLE DE SALON EXTENSIBLE AVEC PLATEAUX TOURNANTS- SYNCHRONISÉS EN VERRE. PIÈTEMENT EN BOIS, SUPPORTS EN ACIER LAQUÉ OU GALVANISÉ.

AUSZIEHBARER COUCHTISCH MIT SYNCHRON DREHBAREN KRISTALLGLASPLATTEN. BASIS AUS HOLZ, TRÄGER AUS LACKIERTEM ODER GALVANISIERTEM STAHL.

SINUOSO



SINUOSO *design A. Casati*

SINUOSO *VariActions*



BASE & SUPPORTS 10 MATT WHITE - TOPS INVISIBLE WHITE / 00 NATURAL GLASS



BASE & SUPPORTS 44 ANTRACITE - TOPS STONE BLACK STONE / 00 NATURAL GLASS



BASE & SUPPORTS 44 ANTRACITE - TOPS DIAMOND CREAM

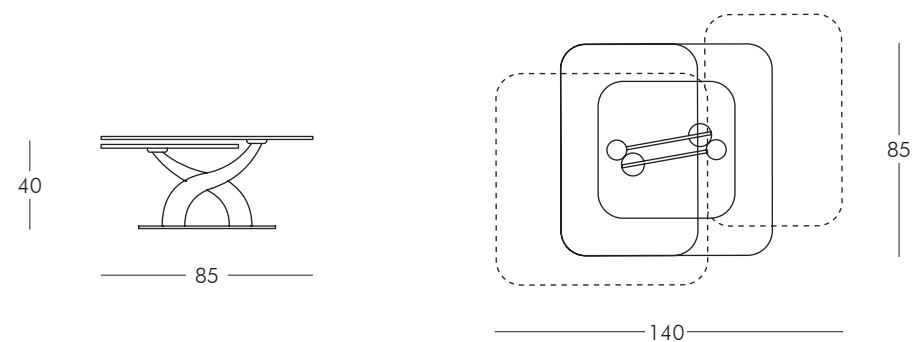

TAVOLINO ESTENSIBILE CON PIANI GIREVOLI SINCRONIZZATI DISPONIBILI IN VETRO O CERAMICA. BASE E SUPPORTI IN FINITURE VERNICIATE. IL TAVOLINO È DOTATO DI UN MECCANISMO DI ROTAZIONE SINCRONIZZATO, CHE CONSENTE UN'AMPIA MODULAZIONE DELLA FORMA.

EXTENSIBLE COCKTAIL TABLE WITH SYNCHRONIZED REVOLVING TOPS IN GLASS OR CERAMIC SELECTIONS. BASE AND SUPPORTS IN PAINTED FINISHINGS. THE BASE IS EQUIPPED WITH A MECHANISM FOR THE SYNCHRONIZED ROTATION OF THE TOPS THAT ALLOW AMPLE MODULATION OF THE SHAPE.

TABLE DE SALON AVEC PATEAUX DISPONIBLES DANS TOUTES LES FINITIONS CÉRAMIQUE OU EN VERRE. BASE ET SUPPORTS EN ACIER LAQUÉ. LA BASE EST EQUIPÉE D'UN MÉCANISME DE ROTATION SYNCHRONISÉE QUI PERMET UNE GRANDE VARIÉTÉ DE POSITIONS.

AUSZIEHBARER COUCHTISCH MIT KERAMIKPLATTEN UND KRISTALLGLAS. BASIS UND TRAGER AUS LACKIERTEM STAHL. DER BESONDERE MECHANISMUS ERLAUBT ES DEN PLATTEN VIELFALTIGE POSIZIONEN EINZUNEHMEN.

THETA *design A. Casati*

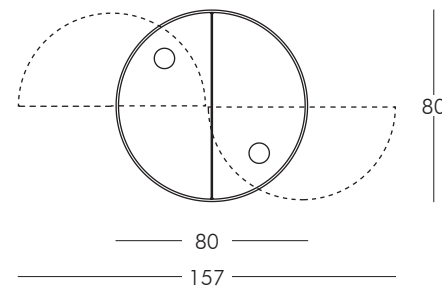
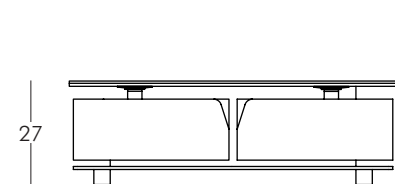

TAVOLINO ROTONDO APRIBILE CON PIANI IN CERAMICA O IN CRISTALLO. BASE E CASSETTI DISPONIBILI NELLE FINITURE VERNICIATE. DOTATO DI MECCANISMO PER L'APERTURA SINCRONIZZATA DEI 2 CASSETTI.

EXTENSIBLE ROUND COCKTAIL TABLE WITH CERAMIC STONE AND PORCELAIN SELECTIONS OR GLASS TOP. BASE AND DRAWERS AVAILABLE IN PAINTED FINISHINGS. EQUIPPED WITH A MECHANISM FOR THE SYNCHRONIZED OPENING OF THE 2 DRAWERS.

TABLE DE SALON RONDE AVEC PLATEAUX DISPONIBLES DANS TOUTES LES FINITIONS CÉRAMIQUE OU EN VERRE. BASE ET TIROIRS DISPONIBLES EN FINITION LAQUÉE, ÉQUIPÉE D'UN MÉCANISME POUR L'OUVERTURE SYNCHRONISÉE DES 2 TIROIRS.

AUSZIEHBARER RUNDER COUCHTISCH MIT KERAMIK - UND KRISTALLGLAS PLATTEN. GESTELL UND SCHUBLADEN IN LACKIERTEN AUSFUHRUNGEN. AUSGESTATTET MIT EINEM MECHANISMUS FÜR DIE SYNCHRONISIERTE ERÖFFNUNG DER 2 SCHUBLADEN.



THETA SHELF *design A. Casati*

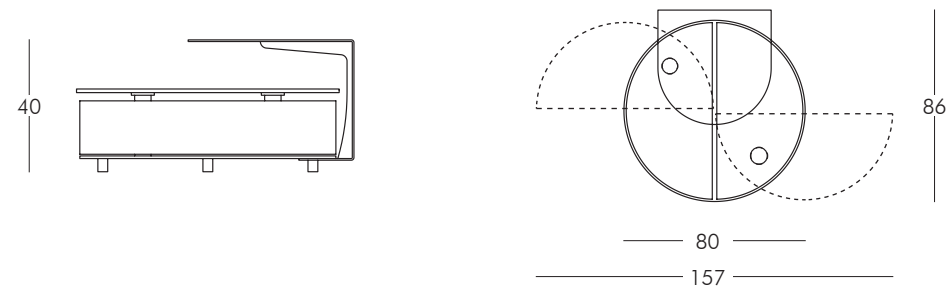

TAVOLINO ROTONDO APRIBILE CON PIANI IN CERAMICA O IN VETRO. BASE E CASSETTI DISPONIBILI NELLE FINITURE VERNICIATE. FORNITO DI RIPIANO LATERALE AGGIUNTIVO DISPONIBILE NELLE FINITURE VERNICIATE, IL TAVOLINO É DOTATO DI MECCANISMO PER L'APERTURA SINCRONIZZATA DEI DUE CASSETTI.

EXTENSIBLE ROUND COCKTAIL TABLE WITH CERAMIC STONE AND PORCELAIN SELECTIONS OR GLASS TOP. BASE AND DRAWERS AVAILABLE IN PAINTED FINISHINGS. PROVIDED WITH ADDITIONAL LATERAL SHELF AVAILABLE IN PAINTED FINISHINGS AND EQUIPPED WITH A MECHANISM FOR THE SYNCHRONIZED OPENING OF THE 2 DRAWERS.

TABLE DE SALON RONDE AVEC PLATEAUX DISPONIBLES DANS TOUTES LES FINITIONS CÉRAMIQUE OU EN VERRE. BASE ET TIROIRS DISPONIBLES EN FINITION LAQUÉE. ÉQUIPÉE D'UNE TABLETTE LATÉRALE SUPPLÉMENTAIRE DISPONIBLE DANS LES FINITIONS LAQUÉES ET D'UN MÉCANISME POUR L'OUVERTURE SYNCHRONISÉE DES 2 TIROIRS.

AUSZIEHBARER RUNDE COUCHTISCH MIT KERAMIKKOLLEKTION UND KRISTALLGLAS. BASIS UND SCHUBLADEN AUS LACKIERTEM AUSFUHRUNGEN. AUSGESTATTET MIT EINEM ZUSÄTZLICHEN SEITLICHEN REGAL IM LACKIERTEN AUSFUHRUNGEN UND MIT EINEM MECHANISMUS ZUM SYNCHRONISIERTEN ÖFFNEN DER 2 SCHUBLADEN .



SHEDIR *design A. Casati*

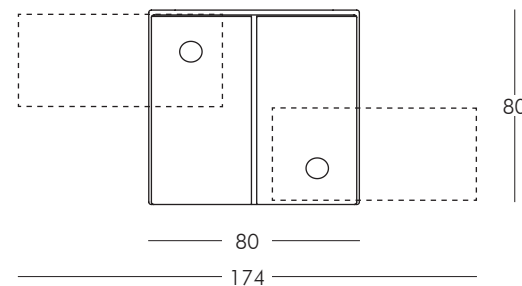
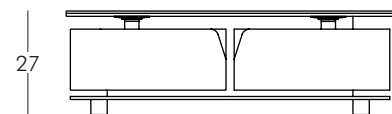
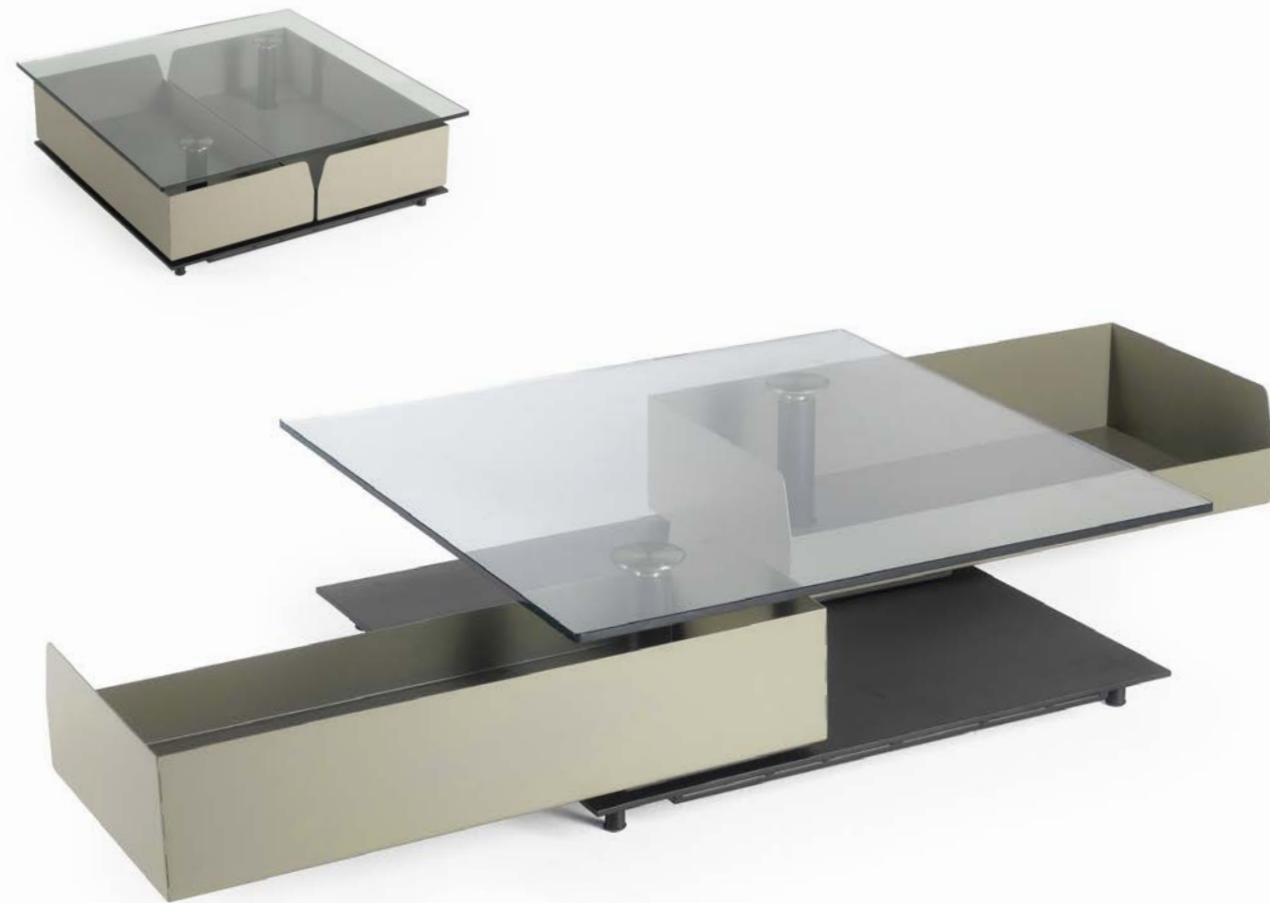

TAVOLINO QUADRATO APRIBILE CON PIANI IN CERAMICA O IN VETRO. BASE E CASSETTI DISPONIBILI NELLE FINITURE VERNICIATE. DOTATO DI MECCANISMO PER L'APERTURA SINCRONIZZATA DEI DUE CASSETTI.

EXTENSIBLE SQUARE COCKTAIL TABLE WITH CERAMIC STONE AND PORCELAIN SELECTIONS OR GLASS TOP. BASE AND DRAWERS AVAILABLE IN PAINTED FINISHINGS. EQUIPPED WITH A MECHANISM FOR THE SYNCHRONIZED OPENING OF THE 2 DRAWERS.

TABLE DE SALON CARRÉE AVEC PLATEAUX DISPONIBLES DANS TOUTES LES FINITIONS CÉRAMIQUE OU EN VERRE. BASE ET TIROIRS DISPONIBLES EN FINITION LAQUÉE, ÉQUIPÉE D'UN MÉCANISME POUR L'OUVERTURE SYNCHRONISÉE DES 2 TIROIRS.

AUSZIEHBARER QUADRATISCHER COUCHTISCH MIT KERAMIK - UND KRISTALLGLAS PLATTEN. GESTELL UND SCHUBLADEN IN LACKIERTEN AUSFUHRUNGEN. AUSGESTATTET MIT EINEM MECHANISMUS FÜR DIE SYNCHRONISIERTE ERÖFFNUNG DER 2 SCHUBLADEN.



ALTAIR



ALTAIR *design A. Casati*

TAVOLINO ESTENSIBILE CON 5 PIANI IN CRISTALLO O CERAMICA. DOTATO DI UN INNOVATIVO MECCANISMO SINCRONIZZATO DI APERTURA CHE PERMETTE AI 4 CRISTALLI DI APRIRSI CON UN SOLO GESTO. SUPPORTI IN ACCIAIO VERNICIATO O CROMATO.

EXTENSIBLE COFFEE TABLE WITH 5 GLASS OR CERAMIC TOPS. EQUIPPED WITH AN INNOVATIVE SYNCHRONIZED MECHANISM THAT ALLOW THE 4 TOPS TO BE OPENED AT ONCE, WITH A SIMPLE GESTURE. SUPPORTS IN PAINTED OR CHROMED STEEL.

TABLE DE SALON EXTENSIBLE AVEC 5 PLATEAUX EN VERRE OU CERAMIQUE. EQUIPÉE D'UN MÉCANISME SYNCHRONISÉ QUI PERMET L'OUVERTURE SIMULTANÉE DES 4 PLATEAUX. SUPPORTS EN ACIER LAQUÉ OU CHROMÉ.

AUSZIEHBARER COUCHTISCH MIT 5 PLATTEN AUS KRISTALLGLAS ODER KERAMIK. AUSGESTATTET MIT EINER INNOVATIVEN SYNCHRONISIERTEN MECHANISMUS, DIE MIT EINER EINZIGEN BEWEGUNG DIE 4 GLASPLATTEN ERLAUBT SICH ZU ÖFFNEN. TRÄGER AUS VERCHROMTEM ODER LACKIERTEM STAHL.

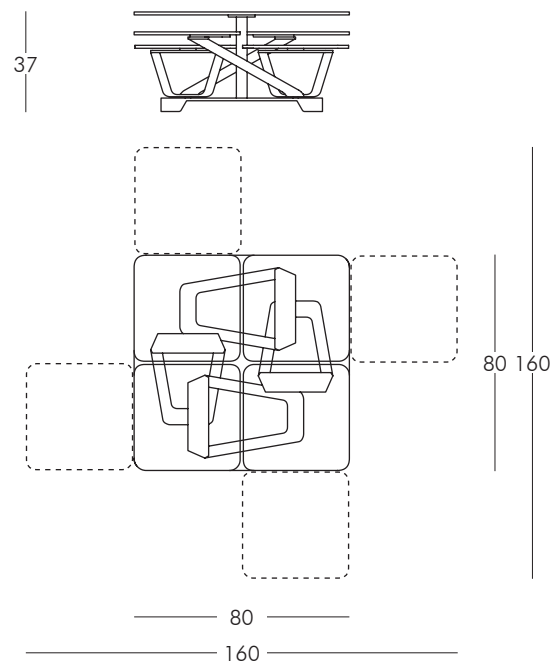

PHOBOS



PHOBOS *design A. Casati*

TAVOLINO ESTENSIBILE CON 3 PIANI IN CRISTALLO O CERAMICA. DOTATO DI UN INNOVATIVO MECCANISMO SINCRONIZZATO DI APERTURA CHE PERMETTE AI 2 CRISTALLI DI APRIRSI CON UN SOLO GESTO. SUPPORTI IN ACCIAIO VERNICIATO O CROMATO.

EXTENSIBLE COFFEE TABLE WITH 3 GLASS OR CERAMIC TOPS. EQUIPPED WITH AN INNOVATIVE SYNCHRONIZED MECHANISM THAT ALLOW THE 2 TOPS TO BE OPENED AT ONCE WITH A SIMPLE GESTURE. SUPPORTS IN PAINTED OR CHROMED STEEL.

TABLE DE SALON EXTENSIBLE AVEC 3 PLATEAUX EN VERRE OU CERAMIQUE. EQUIPEE D'UN MECANISME SYNCHRONISE, QUI PERMET L'OUVERTURE SIMULTANEE DES 2 PLATEAUX. SUPPORTS EN ACIER LAQUE OU CHROME.

AUSZIEHBARER COUCHTISCH MIT 3 PLATTEN AUS KRISTALLGLAS ODER KERAMIK. AUSGESTATTET MIT EINER INNOVATIVEN SYNCHRONISIERTEN MECHANISMUS, DIE MIT EINER EINZIGEN BEWEGUNG DIE 2 GLASPLATTEN ERLAUBT SICH ZU OEFFNEN. TRÄGER AUS VERCHROMTEM ODER LACKIERTEM STAHL.

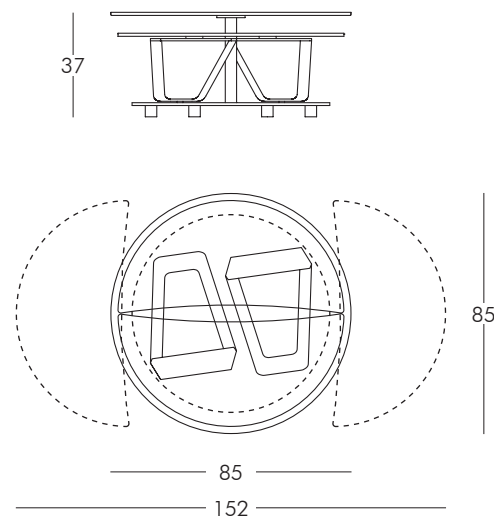

CHARMING MUSES

STYLISH CHAIRS



VANITY CHAIRS

COLLECTION

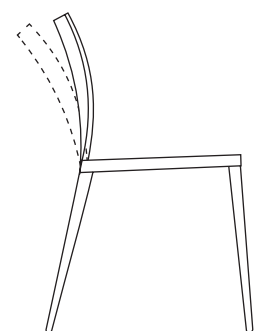

JULIETTE
PAG 251

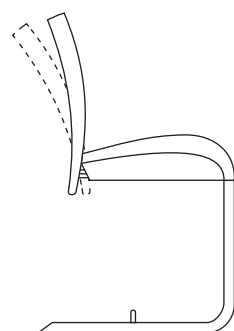

ISOTTA
PAG 253

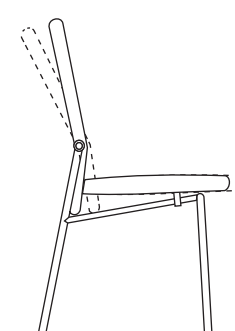

GLISETTE
PAG 255

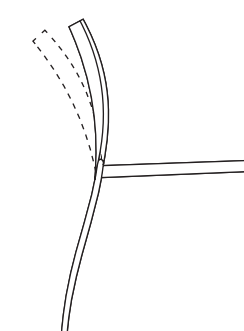

BABETTE
PAG 257



GLISETTE. CHAISE DOTÉE D'UN MÉCANISME COULISSANT. GRÂCE À UNE SIMPLE PRESSION, ON PEUT CHOISIR À VOLONTÉ ET PROGRESSIVEMENT L'INCLINAISON ENTRE L'ASSISE ET LE DOSSIER POUR UN MAXIMUM DE CONFORT.

JULIETTE, ISOTTA, BABETTE. CHAISES DISPONIBLES EN VERSION FIXE OU RÉGLABLE, POUR OBTENIR LE MAXIMUM DE CONFORT ERGONOMIQUE EN MODIFIANT L'INCLINAISON DU DOSSIER AU MOYEN D'UN MÉCANISME À PISTON SIMPLE OU RÉGLABLE.

GLISETTE. DIE STÜHLE SIND MIT EINEM SPEZIELL GLEITENDEN RELAXMECHANISMUS AUSGESTATTET DER DIE GEOMETRIE ZWISCHEN SITZ UND LEHNE NACH BELIEBEN VERÄNDERT UND SO HÖCHSTEN SITZKOMFORT UND ERGONOMIE BIETET.

JULIETTE, ISOTTA, BABETTE. DIE STÜHLE KÖNNEN MIT ZWEI VERSCHIEDENEN RELAXMECHANISMEN AUSGESTATTET WERDEN. DIE FREIE ODER REGULIERBARE GASFEDER VERBINDET ERGONOMIE MIT HÖCHSTEM SITZKOMFORT.

GLISETTE. SEDIA DOTATA DI UNO SPECIALE MECCANISMO A SLITTA CHE CONSENTE, CON UNA SEMPLICE PRESSIONE, DI VARIARE A PIACERE E PROGRESSIVAMENTE L'ANGOLAZIONE TRA SEDUTA E SCHIENALE PER IL MASSIMO DEL CONFORT ERGONOMICO.

JULIETTE, ISOTTA, BABETTE. DISPONIBILI NELLA VERSIONE A SEDUTA FISSA O MODULABILE, PER OTTENERE IL MASSIMO DEL CONFORT ERGONOMICO VARIANDO L'INCLINAZIONE DELLO SCHIENALE MEDIANTE UN MECCANISMO A PISTONE LIBERO O REGOLABILE.

GLISETTE. THE CHAIR ARE EQUIPPED WITH A SPECIAL GLIDING MECHANISM THAT ALLOWS TO MODULATE THE ALIGNMENT BETWEEN SEAT AND BACK, OFFERING SUPERIOR SITTING COMFORT AND ERGONOMIC POSTURE.

JULIETTE, ISOTTA, BABETTE. THE CHAIRS CAN BE EQUIPPED WITH TWO DIFFERENT MOTION DEVICES, ACTIVATED BY FREE OR ADJUSTABLE GAS PISTON TO MODULATE THE POSITION OF THE BACK FOR SUPERIOR SITTING COMFORT AND ERGONOMIC POSTURE.

JULIETTE *design G. Mastro*

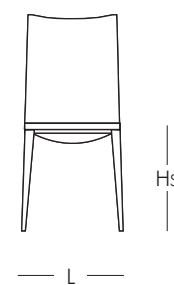
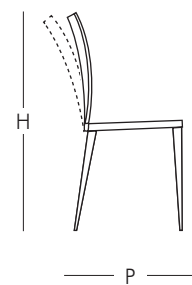

- L P H
 • 43 x 53 x 92 cm
 Hs: 45 cm

SEDIA IMBOTTITA CON STRUTTURA IN ACCIAIO CROMATO O VERNICIATO. SEDILE E SCHIENALE ERGONOMICI, CON RIVESTIMENTO IN PELLE. DISPONIBILE NELLA VERSIONE CON SCHIENALE REGOLABILE A MOLLA LIBERA "M" PER MODULARE CON MAGGIOR PRECISIONE LA GEOMETRIA DELLA SEDUTA.

UPHOLSTERED CHAIR WITH FRAME IN PAINTED OR CHROMED STEEL. ERGONOMIC SEAT AND BACK COVERED WITH LEATHER. AVAILABLE WITH AUTOMATIC GAS SPRING "M" TO MODULATE THE GEOMETRY OF THE SEAT WITH PRECISION.

CHAISE REMBOURRÉE AVEC STRUCTURE EN ACIER LAQUÉ OU GALVANISÉ. SIÈGE ET DOSSIER ERGONOMIQUES AVEC GARNITURE EN PEAU. DISPONIBLE AVEC RESSORT A GAZ "M" POUR FAVORISER TOUTE EXIGENCES DE POSITION.

POLSTERSTUHL MIT GESTELL AUS LACKIERTEM ODER VERCHROMTEM STAHL. SITZ UND RÜCKENBEZUG ABNEHMBAR IN LEDER. IN DEN RÜCKENVERSIONEN, MIT RELAXMECHANISMUS "M" FÜR ERGONOMIE UND HÖCHSTEN SITZKOMFORT.

JULIETTE *VariActions*



FRAME 37 CHROME - SEAT AND BACK 5000 WHITE



FRAME 37 CHROME - SEAT AND BACK 5320 CAPPUCCINO



FRAME 37 CHROME - SEAT AND BACK 5310 DARK GREY

ISOTTA design D. D'Urbino P. Lomazzi

ISOTTA VariActions



FRAME 37 CHROME - SEAT AND BACK 5000 WHITE



FRAME 37 CHROME - SEAT AND BACK 992TM BEIGE



FRAME 37 CHROME - SEAT AND BACK 5210 DARK RED

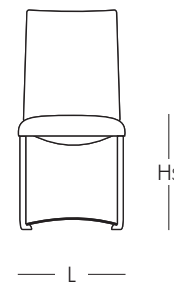
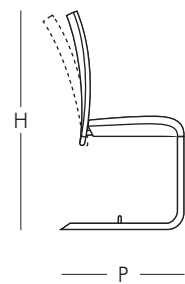

- L P H
 • 47 x 53 x 91cm
 Hs: 45 cm

SEDIA IMBOTTITA CON STRUTTURA IN ACCIAIO CROMATO O VERNICIATO. SEDILE E SCHIENALE ERGONOMICI, CON RIVESTIMENTO IN PELLE. DISPONIBILE NELLA VERSIONE CON SCHIENALE REGOLABILE A MOLLA LIBERA "M" PER MODULARE CON MAGGIOR PRECISIONE LA GEOMETRIA DELLA SEDUTA.

UPHOLSTERED CHAIR WITH FRAME IN PAINTED OR CHROMED STEEL. ERGONOMIC SEAT AND BACK COVERED WITH LEATHER. AVAILABLE WITH AUTOMATIC GAS SPRING "M" TO MODULATE THE GEOMETRY OF THE SEAT WITH PRECISION.

CHAISE REMBOURRÉE AVEC STRUCTURE EN ACIER LAQUÉ OU GALVANISÉ. SIÈGE ET DOSSIER ERGONOMIQUES AVEC GARNITURE EN PEAU. DISPONIBLE AVEC RESSORT A GAZ "M" POUR FAVORISER TOUTE EXIGENCES DE POSITION.

POLSTERSTUHL MIT GESTELL AUS LACKIERTEM ODER VERCHROMTEM STAHL. SITZ UND RÜCKENBEZUG ABNEHMBAR IN LEDER. IN DEN RÜCKENVERSIONEN, MIT RELAXMECHANISMUS "M" FÜR ERGONOMIE UND HÖCHSTEN SITZKOMFORT.

GLISETTE *design D. D'Urbino P. Lomazzi*

GLISETTE *VariActions*



FRAME 37 CHROME - SEAT AND BACK 5000 WHITE



FRAME 37 CHROME - SEAT AND BACK GREY



FRAME 37 CHROME - SEAT AND BACK 5300 BLACK

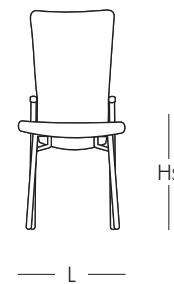
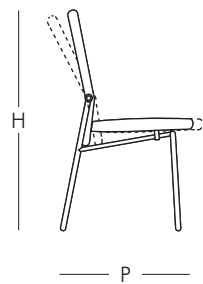

- L P H
 • 49 x 60 x 96 cm
 Hs: 45 cm

SEDIA IMBOTTITA CON STRUTTURA IN ACCIAIO CROMATO O VERNICIATO. SEDILE E SCHIENALE CON RIVESTIMENTO IN PELLE. DOTATA DI UN MECCANISMO CHE CONSENTE DI VARIARE A PIACERE ED IN MODO PROGRESSIVO LA GEOMETRIA DELLA SEDUTA.

UPHOLSTERED CHAIR WITH FRAME IN PAINTED OR CHROMED STEEL. ERGONOMIC SEAT AND BACK COVERED WITH LEATHER. EQUIPPED WITH A RELAXMECHANISM "R" THAT ALLOWS YOU TO VARY THE GEOMETRY OF THE SEATING WITH A LITTLE PRESSURE TO THE BACKBONE OF THE CHAIR.

CHAISE REMBOURRÉE AVEC STRUCTURE EN ACIER LAQUÉ OU GALVANISÉ. SIÈGE ET DOSSIER ERGONOMIQUES AVEC GARNITURE PEAU. ÉQUIPÉE D'UN MÉCANISME QUI, PAR UNE LÉGÈRE PRESSION DES REINS, PERMET DE MODIFIER PROGRESSIVEMENT LA GÉOMÉTRIE DE LA CHAISE.

POLSTERSTUHL MIT GESTELL AUS LACKIERTEM ODER VERCHROMTEM STAHL. SITZ UND RÜCKENBEZUG IN LEDER FÜR ERGONOMIE UND KOMFORT MIT EINSTELLBAREM RELAXMECHANISMUS "R" AUSGESTATTET: SITZ UND RÜCKEN GLEITEN AUF WUNSCH IN RELAXPOSITION.

BABETTE *design D. D'Urbino P. Lomazzi*

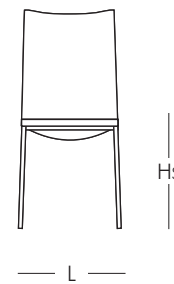
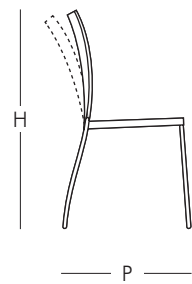

- L P H
 • 43 x 53 x 92 cm
 Hs: 45 cm

SEDIA IMBOTTITA CON STRUTTURA IN ACCIAIO CROMATO O VERNICIATO. SEDILE E SCHIENALE ERGONOMICI, CON RIVESTIMENTO IN PELLE. DISPONIBILE NELLA VERSIONE CON SCHIENALE REGOLABILE A MOLLA LIBERA "M" PER MODULARE CON MAGGIOR PRECISIONE LA GEOMETRIA DELLA SEDUTA.

UPHOLSTERED CHAIR WITH FRAME IN PAINTED OR CHROMED STEEL. ERGONOMIC SEAT AND BACK COVERED WITH LEATHER. AVAILABLE WITH AUTOMATIC GAS SPRING "M" TO MODULATE THE GEOMETRY OF THE SEAT WITH PRECISION.

CHAISE REMBOURRÉE AVEC STRUCTURE EN ACIER LAQUÉ OU GALVANISÉ. SIÈGE ET DOSSIER ERGONOMIQUES AVEC GARNITURE EN PEAU. DISPONIBLE AVEC RESSORT A GAZ "M" POUR FAVORISER TOUTE EXIGENCES DE POSITION.

POLSTERSTUHL MIT GESTELL AUS LACKIERTEM ODER VERCHROMTEM STAHL. SITZ UND RÜCKENBEZUG ABNEHMBAR IN LEDER. IN DEN RÜCKENVERSIONEN, MIT RELAXMECHANISMUS "M" FÜR ERGONOMIE UND HÖCHSTEN SITZKOMFORT.

BABETTE / BABETTE SOFT *VariActions*



BABETTE - FRAME 37 CHROME - SEAT AND BACK 5310 DARK GREY



BABETTE SOFT - FRAME 37 CHROME - SEAT AND BACK 5270 DARK BROWN



BABETTE SOFT - FRAME 37 CHROME - SEAT AND BACK 5320 CAPPUCCINO



DREAMING MUSES

EMOTIONS
VARIATIONS

MONOLITH *design Naos*



FEET & SIDES GREY - DOORS & TOP CALACATTA

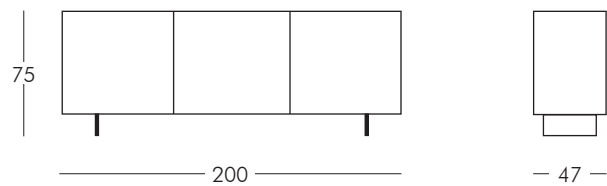

MADIA CONTENITORE 3 ANTE IN LEGNO CON RIVESTIMENTO PIANO SUPERIORE E ANTE IN CERAMICA. RIPIANI INTERNI IN CRISTALLO. CERNIERE CON APERTURA AUTOMATICA E BLOCCO IN CHIUSURA.

THREE DOORS SIDEBOARD IN WOOD WITH TOP AND DOORS COVERED IN CERAMIC. INTERNAL SHELVES IN GLASS. HINGE WITH AUTOMATHIC OPENING SYSTEM AND CLOSING LOCK.

BUFFET AVEC 3 PORTES EN BOIS. PORTES ET PLATEAU SUPERIEUR EN CERAMIQUE. ETAGERES EN VERRE. CHARNIERES A' OUVERTURE AUTOMATIQUE ET STOP DE FERMETURE.

ANRICHTE AUS HOLZ 3 TÜREN. MIT TOP UND TÜREN BEDECKT AUS KERAMIK. INNEN REGALE AUS GLAS. SCHARNIER MIT AUTOMATISCHER ÖFFNUNG SYSTEM UND SCHLISSBLOCK.



UPTOWN CONSOLLE

design A. Casati



FRAME 37 CHROME - TOP BLACK DESIRE



FRAME 37 CHROME - TOP CALACATTA

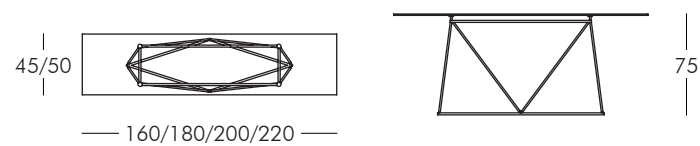

CONSOLLE CON PIANI IN CERAMICA E CRISTALLO. STRUTTURA IN ACCIAIO VERNICIATO O GALVANIZZATO.

CONSOLLE MIT KERAMIKPLATTE UND KRISTALLGLASS. GESTELL AUS LACKIERTEM ODER GALVANISIERTEM STAHL.

CONSOLLE WITH CERAMIC AND GLASS TOP. PAINTED OR GALVANIZED STEEL FRAME.

CONSOLLE AVEC PLATEAU EN CERAMIQUE ET EN VERRE. BASE EN ACIER LAQUEE OU TRAITTE AU BAIN GALVANIQUE.



IMAGE IN ACTION NAOS

A STORY IN MOTION

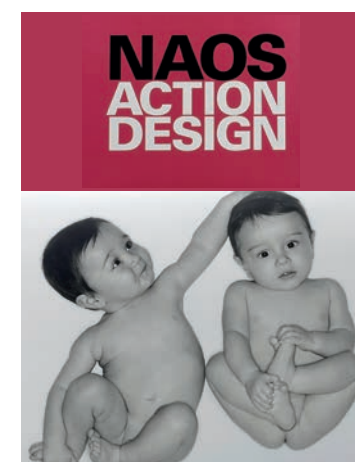
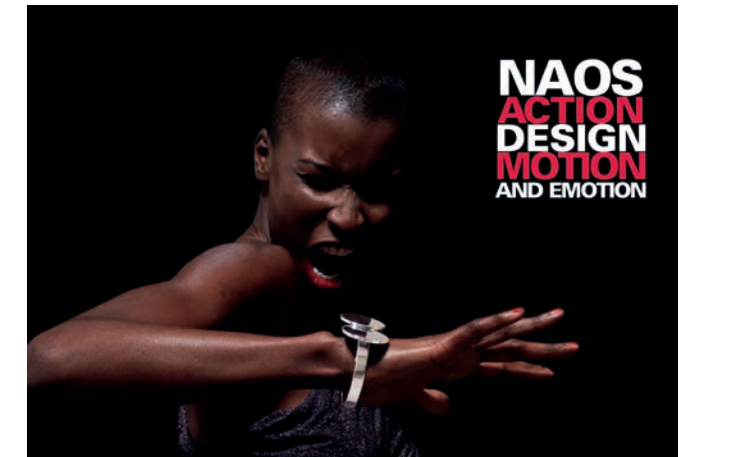
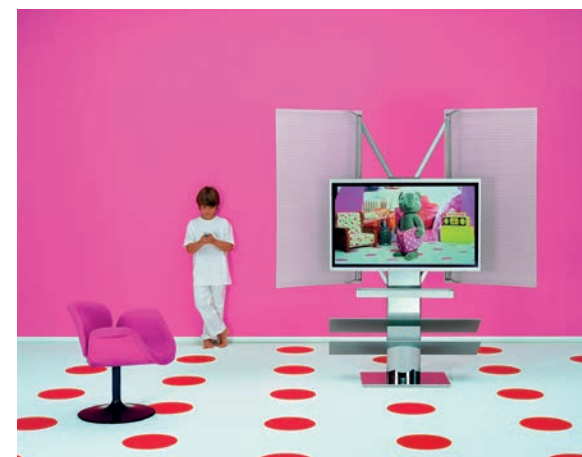
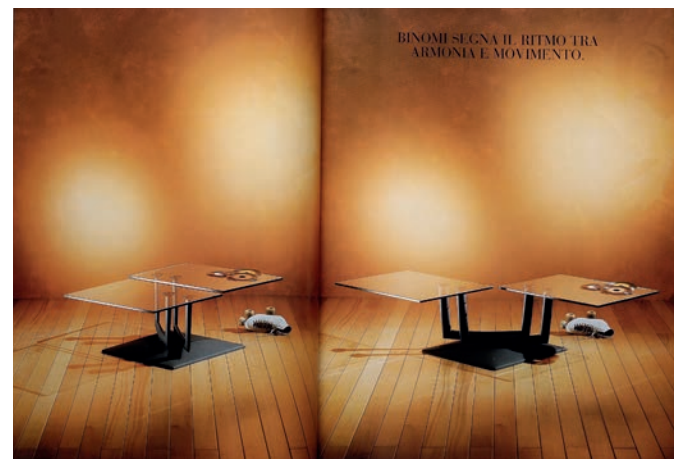

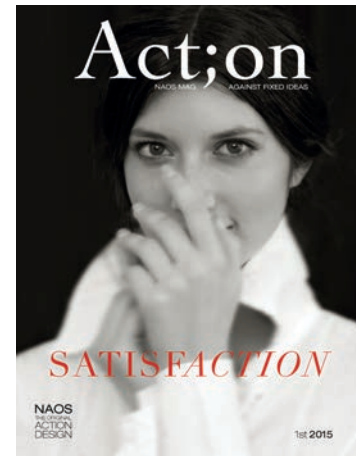

HAPPY NESS MOVES

Il pensiero si muove, lo sguardo si muove, la felicità si muove. La vita è movimento. Thought moves, a gaze moves, happiness moves. Life is movement. The pencil moves, the regard looks, it looks to change. La vie est mouvement. Der Gedanke ist in Bewegung, der Blick ist in Bewegung, das Glück ist in Bewegung. Das Leben ist Bewegung.

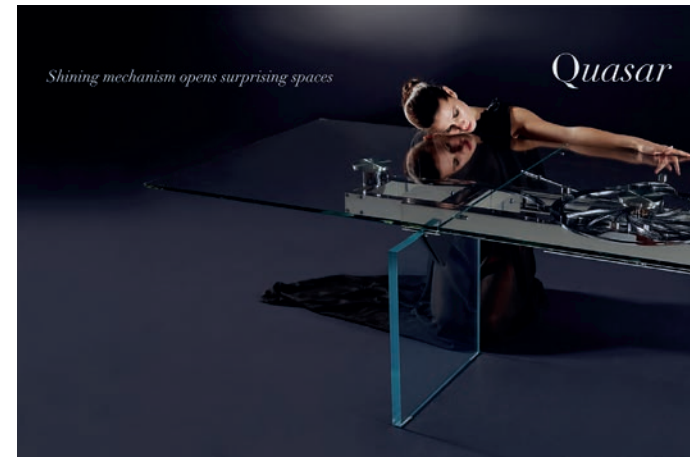
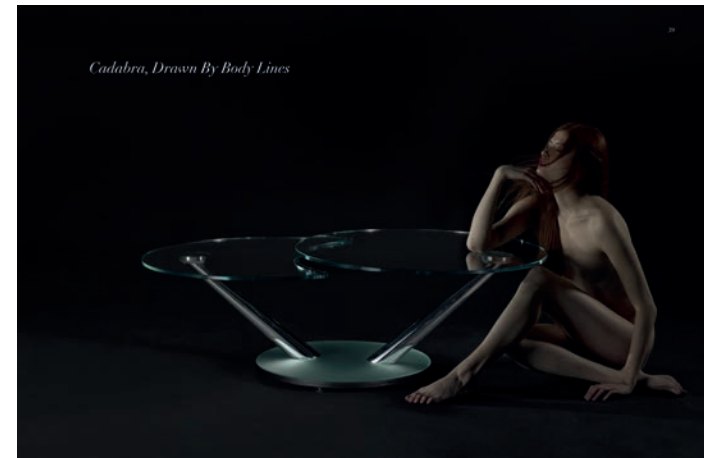



the ART of *KNOW* HOW

Il know-how è un'arte, qualcosa che si acquisisce nel tempo. Dall'originario progetto di industrial design nato sull'idea del movimento, nel corso degli anni Naos Action Design si è distinta nei mercati internazionali per la sua alta qualità produttiva e per la costante ricerca ed innovazione. È questa l'arte del fare, l'arte del coniugare movimento ed emozione. Parliamone con Thomas Morbidelli presidente e direttore creativo.

Know-how is an art, something that is acquired over time. From the original industrial design project born FROM the idea of movement, Naos Action Design distinguished itself over the years in international markets for its high quality production and constant research and innovation. This is the art of doing, the art of combining movement and emotion. Let's talk with Thomas Morbidelli, president and creative director.

Le know-how est un art, acquis au fil du temps. Depuis le projet de design industriel original né de l'idée de mouvement, Naos Action Design s'est distinguée au fil des ans sur les marchés internationaux pour sa qualité de production élevée, sa recherche constante et son innovation. C'est l'art de faire, l'art de combiner le mouvement et l'émotion. Discutons avec Thomas Morbidelli, président et directeur de la création.

Know-How ist eine Kunst die man mit der Zeit erwirbt. Vom ursprünglichen Industriedesign-Projekt, entstanden aus der Idee über Bewegung, hat sich Naos Action Design, im Laufe der Jahre auf internationaler Ebene durch seine hohe Produktionsqualität und konstante Forschung und Innovation ausgezeichnet. Dies ist die Kunst des Tuns, die Kunst Bewegung und Emotion zu kombinieren. Wir reden darüber mit Thomas Morbidelli, Präsident und Kreativdirektor.

Come nasce il progetto dell'Action Design?

Alla metà degli anni '80, nel nostro paese il design industriale era in piena fase espansiva. Veniva riconosciuta in tutto il mondo la qualità produttiva e la ricerca formale delle aziende del design italiano. Tuttavia questa positività indusse a distorsioni, sino alle derive di un formalismo astratto o ingiustificato, non sempre premiato dal pubblico. In questo contesto mio padre Mario Morbidelli (fondatore di Naos) immagina un nuovo scenario ed insieme ad un piccolo, prestigioso, gruppo di designer sperimenta, progetta e propone una collezione di complementi d'arredo accomunati da una particolare caratteristica: il movimento. E' così che nasce Naos.

Da cosa era costituita quella prima collezione?

Si trattava di circa una dozzina tra tavoli e tavolini che si estendevano, si ampliavano, si trasformavano sincreticamente mediante insoliti, originali meccanismi di movimento. Naos da un lato progetta il futuro cioè un superamento delle innumerevoli derive del formalismo fine a se stesso, dall'altra tocca con mano il presente che richiede di trovare un'area meno battuta, un'apertura di un mercato prima inesplorato: oggetti d'arredo che animano la nostra casa.

Quali designer furono coinvolti?

Inizialmente lo studio Arnaldo Gamba e Leila Guerra a cui si affiancarono quasi da subito Donato D'Urbino e Paolo Lomazzi, continuatori delle esperienze dell'Italian Style degli anni '70, con cui avevano ottenuto riconoscimenti internazionali, con oggetti tuttora presenti al Moma di New York. Si sono poi aggiunte le esperienze con Denis Santachiara, inventore di oggetti icona negli anni '90, con Mario Marengo, ironico inguaribile anche nell'immaginare un tavolino e poi Giusy Mastro che ha ampliato la nostra collezione con uno studio sulle sedute, ed ancora Yoshiharu Hatano che ha attribuito al disegno dei nostri tavoli un nuovo rigore grafico, che proviene dalla sofisticata essenzialità della sua cultura d'origine, il Giappone.

Alla base della riconoscibilità del marchio Naos ci sono le meccaniche del movimento.

È vero i meccanismi di movimento sono l'invenzione da cui parte il progetto e che tuttora contraddistingue tutta la produzione. Tali meccanismi consentono al prodotto di muoversi all'interno dello spazio abitativo, non solo estendendosi come per i tavoli allungabili, ma anche spostando i piani in varie direzioni, alzandoli o abbassandoli, aprendosi e chiudendosi e così via. Tutto ciò con gesti semplicissimi.

I meccanismi di movimento originariamente occultati all'interno delle strutture, in alcuni prodotti più recenti vengono esposti visivamente a enfatizzare l'aspetto di "macchina estetica domestica".

In più, alcuni di loro, oggi sono stati dotati di comandi remoti, telecomandi wireless, che aprono nuovi scenari alla ricerca.

A questi ingegnosi meccanismi si associa poi la scelta dei materiali.

Naos possiede un profondo know how produttivo, con impianti di galvanizzazione d'avanguardia. Metallo cromato e acciaio sono quindi le materie principali associate al cristallo nelle varie colorazioni. Ma non mancano gli accostamenti con altre materie, altre finiture, la leggerezza dell'alluminio, più raramente il legno, di recente la ceramica.

Tutti elementi che conferiscono al prodotto un'identità di oggetto rigoroso, solido, consistente.

Siamo convinti che l'uso di questi materiali consenta di interpretare i nostri prodotti nel modo più corretto. Oggetti che fanno parte a pieno titolo dell'area del mobile contemporaneo, con un forte impatto visivo, corrispondente a una particolare idea di arredo in cui il valore e la qualità produttiva sono esplicitamente rappresentati, per la consistenza dei componenti.

Si tratta tuttavia di oggetti "difficili" da produrre.

Questo è un altro dei nostri plus. Sono in tanti a fare tavoli estensibili in acciaio e cristallo. Ma i nostri sono "inimitabili". Far congiungere due piani in cristallo con un movimento fluido e con un gesto semplicissimo, è pura ingegneria costruttiva. Sino a qualche tempo fa capitava che i nuovi clienti con cui entravamo in contatto pensassero che dietro la nostra tecnologia costruttiva ci fosse un'azienda tedesca. Ed invece è tutto rigorosamente e orgogliosamente Made in Italy.

Tutto questo fa pensare ad un "sistema di valori" che va oltre al prodotto e coinvolge una filosofia produttiva.

È questa la grande mission dell'Action design. L'idea di movimento connaturata al prodotto in un certo senso è una espressione della più interna identità in movimento dell'azienda Naos. Non è solo il prodotto in movimento ma un'intera filosofia aziendale. In un mercato globale, mutevole, fluido, con scenari sempre più dinamici è necessario che il flusso delle sollecitazioni, delle proposte, sia continuo, vario ma coerente. Il flusso è movimento, il movimento è l'Action Design.

How was the Action Design project born?

In the mid-eighties in Italy, Design was in its full expansion. All around the globe, Italian design was recognized and imitated. Despite that, this constant research of new shapes failed to show coherence over time. In this context, my father, Mario Morbidelli (founder of Naos) imagines a new scenario: with a group of designers research, realize, and propose a collection of interior design accessories with a common trait of movement. This is Naos origin.

What were the elements of that first collection?

It was about a dozen extendable tables and coffee tables, able to transform in shape through original moving mechanisms. On one hand, Naos designed the future, interpreted as a conscious progression from static and self-referential formality. On the other hand, Naos faced the present, researching a new area in the market: interior design able to animate our homes.

Which designers were involved?

Initially, Arnaldo Gamba and Leila Guerra's studio—almost immediately sustained by Donato D'Urbino and Paolo Lamazzi, whose designs in the Italian style of the seventies are still displayed today at New York's Museum of Modern Art (MOMA). Denis Santachiara, creator of iconic objects in the nineties, joined the group together with the ironic touch of Mario Marengo. Then Giusy Mastro came aboard, with a study on seating solutions, followed by Yoshiharu Hatano, who added to our tables a new graphic linearity inherited from the sophistication of his Japanese background.

"Mechanics of movement" define Naos brand's unicity.

Correct, moving mechanisms are the source of invention that still today characterize our entire process. Those mechanisms allow a wide range of movements in the living space—not simply extending, but also shifting the tops in different directions, raising or dropping them, opening or closing them, and so forth. All of this with extremely simple gestures. The originally hidden mechanisms, engraved in the structure in some recent products, are visually exposed to emphasize the value of a "domestic aesthetic machine". Furthermore, some of them are equipped with remote controls and wireless controls that open new scenarios for research.

To these ingenious machines, you can match your choice of materials.

Naos encompasses a profound productive know-how, with cutting edge galvanization plants. Chromed metal and stainless steel are then our favorite materials, usually paired with different shades of crystal. But of course we love to combine it also with other materials, work with different finishes—for example the lightness of aluminum, sometimes wood, recently ceramic.

Those are all elements that enrich your work with a strong identity and a rigorous, solid, consistent product.

We believe that the use of those materials conveys the most correct interpretation of our products. Our objects belong in the contemporary furniture category, with a strong visual impact corresponding to a unique concept of interior design. The quality of our production is explicitly expressed with the consistency of the materials.

We are dealing with "difficult" materials to produce.

This is another plus. Many brands are producing extendable steel and crystal tables. But ours are inimitable. To be able to connect two crystal tops with a fluid movement and a simple gesture is pure engineering. A while ago, some clients asked if a German constructor was behind our machines. Actually, everything is strictly and proudly Made in Italy.

This suggests a "system of core values" beyond the product that encompasses a productive philosophy.

This is the great mission of Action Design. The idea of movement is intrinsic to the product. In a way, it is the expression of a more intimate, moving identity of the brand. Not only our products can move; movement is also our company philosophy. In a global, variable, fluid market—with an increasing dynamism—it's important that the flow of our conceptual work is continuous, diverse, but coherent. Flow is movement: movement is Action Design.

Comment le projet de l'Action Design a-t-il vu le jour ?

Au milieu des années 80, le design industriel était en pleine phase d'expansion dans notre pays. La créativité italienne était reconnue dans le monde entier. Cependant cette recherche de formes toujours nouvelles a fini par devenir une recherche qui n'était pas toujours justifiée par des projets cohérents. Dans ce contexte, mon père Mario Morbidelli (fondateur de Naos) a imaginé un nouveau scénario et, avec un groupe de designers, expérimente, conçoit et propose une collection de compléments d'ameublement unis par une caractéristique particulière : le mouvement. Voilà l'origine de Naos.

De quoi la première collection se composait-elle ?

Il s'agissait d'une douzaine de tables grandes ou petites qui s'allongeaient, s'élargissaient et se transformaient synchroniquement grâce à des mécanismes de mouvement originaux. D'un côté, Naos imagine le futur, c'est-à-dire un dépassement de la recherche formelle comme une fin en soi, de l'autre, il est en contact avec le présent qui exige de trouver des sentiers moins battus, une ouverture vers un marché jusqu'à présent inexploré : des éléments d'ameublement qui animent notre intérieur.

Quels designers ont-ils participé ?

Au début, le studio Arnaldo Gamba et Leila Guerra, qui furent presque aussitôt rejoints par Donato D'Urbino et Paolo Lomazzi, continuateurs des expériences de l'Italian Style des années 70 qui leur avaient valu des prix internationaux, grâce à des objets qui sont encore exposés au MoMA de New York. Ce n'est qu'ensuite que sont venues les expériences avec Denis Santachiara, inventeur d'objets emblématiques des années 90, Mario Marengo, dont l'incorrigible ironie se sentait jusque dans sa façon d'imaginer une table, puis Giusy Mastro, qui a enrichi notre collection avec une étude sur les sièges, ou encore Yoshiharu Hatano, qui a donné au dessin de nos tables une nouvelle rigueur graphique provenant de l'essentialité sophistiquée de sa culture d'origine, la japonaise.

Les mécaniques du mouvement sont la caractéristique distinctive de la marque Naos.

En effet, les mécanismes de mouvement sont l'invention dont part le projet et qui aujourd'hui encore caractérise toute la production. Ces mécanismes permettent au produit de se mouvoir dans l'espace domestique, non seulement en s'agrandissant, comme les tables extensibles, mais aussi en déplaçant les plans dans différentes directions, en les élevant ou les abaissant, en les ouvrant ou les fermant et ainsi de suite. Tout cela grâce à des gestes très simples. Dans certains produits récents, les mécanismes de mouvement jadis cachés à l'intérieur des structures sont exposés à la vue pour souligner l'aspect de « machine esthétique domestique ». De surcroît, certains produits ont à présent été équipés de télécommandes sans fil qui ouvrent de nouveaux scénarios pour la recherche.

A ces mécanismes ingénieux s'ajoute ensuite le choix des matériaux.

Naos possède un savoir-faire productif profond, avec des machines de galvanisation à l'avant-garde. Le métal chromé et l'acier sont donc les matériaux principaux associés à différentes teintes de cristal. Mais les mariages avec d'autres matériaux et d'autres types de finition ne manquent pas, comme la légèreté de l'aluminium, plus rarement le bois ou, récemment, la céramique.

Autant d'éléments qui confèrent au produit une identité d'objet rigoureux, solide, consistant.

Nous sommes persuadés que l'utilisation de ces matériaux permet d'interpréter nos produits au plus juste. Des objets faisant partie du secteur du meuble contemporain à tous les effets, avec un fort impact visuel, et correspondant à une idée particulière d'ameublement dont la valeur et la qualité productive sont explicitement représentées par la consistance des composants.

Il s'agit néanmoins d'objets « difficiles » à produire.

C'est là un autre de nos avantages. Ils sont nombreux à faire des tables extensibles en acier et en céramique. Mais les nôtres sont inimitables. Faire coïncider deux plans en cristal avec un mouvement fluide et un geste simple relève de la pure ingénierie de construction. Jusque tout récemment, certains des clients avec lesquels nous entrons pour la première fois en contact croyaient que notre technologie de construction provenait d'une entreprise allemande. Mais tout est rigoureusement et orgueilleusement made in Italy.

Tout cela fait penser à un « système de valeurs » qui va au-delà du produit pour impliquer une philosophie de production.

C'est la grande mission de l'Action design. En un sens, l'idée de mouvement inhérent au produit est une expression du mouvement de l'identité intime de l'entreprise Naos. Il ne s'agit pas simplement de produits en mouvement, mais d'une véritable philosophie d'entreprise. Dans un marché global, changeant, fluide, avec des scénarios toujours plus dynamiques, il est nécessaire que le flux des sollicitations et des propositions soit continu, varié, mais aussi cohérent. Le flux est mouvement, le mouvement est Action design.

Wie entstand das Projekt des Action Design?

Mitte der Achtziger Jahre war Industriedesign hier in Italien weit verbreitet. Auf der ganzen Welt wurde unsere Kreativität bewundert und anerkannt. Die Suche nach immer neuen Formen ging dann aber so weit, daß diese nicht immer notwendig war, da es keine unterstützenden Konzepte gab. In diesem Zusammenhang mein Vater Mario Morbidelli (Unternehmensgründer von Naos) hat ein neues Szenarium geschaffen und gemeinsam mit einer Gruppe von Designern experimentiert. So entstand der Entwurf für eine Kollektion von Einrichtungsgegenständen die alle ein spezielles Kriterium gemeinsam haben: die Bewegung. Damit ist Naos geboren.

Wie war diese erste Kollektion zusammengestellt?

Es handelte sich dabei um ca. ein dutzend größerer und kleinerer Tische, die sich verlängerten und vergrößerten und sich mit Hilfe echter Bewegungsmechanismen synchron verwandelten. Einerseits konzipiert Naos die Zukunft durch Überwindung einer rein formalen Recherche, andererseits ist Naos in der Gegenwart verankert, die uns vor die Aufgabe stellt einen neuen Wirkungskreis zu schaffen. Die Entdeckung eines neuen Marktes: Einrichtungsgegenstände die unser Heim beleben.

Welche Designer wurden an dem Projekt beteiligt?

Von Anfang an dabei waren das Studio Arnaldo Gamba und Lella Guerra, kurz danach kamen Donato D'Urbino und Paolo Lomazzi dazu, die ihre Erfahrungen aus dem Italian Style der 70er Jahre mitbrachten. mit dem sie großen internationalen Erfolg verbuchen konnten. Selbst heute findet man noch ihre Gegenstände aus dieser Schaffenszeit im Moma von New York. Es folgten Denis Santachiara, ein Erfinder verschiedener Kultobjekte der 90er Jahre, gemeinsam mit Mario Marengo, der auch einen noch so kleinen Tisch mit seiner typischen Ironie neu ersinnt. Dann sind da noch Giusy Mastro, die unsere Kollektion mit einer Studie über Sitzgelegenheiten bereichert und Yoshiharu Hatano, der dem Design unserer Tische eine grafische Präzision verliehen hat, die der klaren Wesentlichkeit seiner japanischen Heimatkultur entspringt.

Der Wiedererkennungswert der Marke Naos liegt bei den Bewegungsmechanismen

Ja, das stimmt, die Bewegungsmechanismen stehen an der Basis dieses Projektes und charakterisieren auch heute noch die gesamte Produktion. Diese Mechanismen erlauben dem Produkt sich im Inneren des Wohnraumes zu bewegen, nicht nur sich wie Tische zu verlängern, sondern auch die einzelnen Flächen in verschiedene Richtungen zu versetzen, indem sie erhöht oder heruntergelassen werden, sich öffnend oder schließend, usw. All dies geschieht mit einfachsten Gesten. Die Bewegungsmechanismen wurden zu Beginn im Inneren der Strukturen versteckt, in einigen neueren Produkten sind sie sichtbar gemacht worden, um den Aspekt der "ästhetischen Maschine zu Hause" zu betonen. Des weiteren, sind einige von ihnen heutzutage mit einer Fernbedienung ausgestattet, die der Entwicklung neue Szenarien eröffnen.

Zu diesen erfinderischen Mechanismen kommt dann noch die Auswahl der Materialien hinzu

Bei der Produktion verfügt Naos über großes know how, mit Galvanisationsanlagen die zur Avantgarde gehören. Chrom Metall und Stahl sind dann das Hauptmaterial und wird gemeinsam mit verschieden farbigem Kristall verarbeitet. Aber es kommen auch neue Materialien hinzu, neue Kombinationen und Endfertigungen z.B. die Leichtigkeit des Aluminiums, etwas seltener Holz, und erst seit kurzem Keramik.

Basismaterialien die dem Produkt die Identität eines präzisen, soliden und konsistenten Gegenstandes verleihen.

Wir sind davon überzeugt, daß der Gebrauch dieser Grundstoffe zu einer genaueren Interpretation unserer Produkte beiträgt. Objekte, die mit vollem Recht als Einrichtungsgegenstände der Gegenwart bezeichnet werden können, da sie unmißverständlich das Konzept einer Wohnungsausstattung vertreten, deren Wert und produktive Qualität durch ihre Beschaffenheit eindeutig sichtbar gemacht wird.

Es handelt sich also um Gegenstände, deren Produktion als "schwierig" bezeichnet werden kann..

Auch dies ist unsere Stärke. Es gibt viele Firmen, die ausziehbare Tische in Stahl und Kristall herstellen. Aber unsere Produkte sind "inimi-table". Zwei Kristallplatten in einer geschmeidigen und einfachen Geste miteinander zu vereinen ist pures Ingenieurwesen. Noch bis vor kurzem kam es vor, daß neue Kunden davon überzeugt waren, daß eine deutsche Firma für die Konstruktionstechnik verantwortlich ist. Hingegen ist alles strikt Made in Italy worauf wir sehr stolz sind.

All dies läßt auf ein "Wertesystem" schließen, das über das Produkt hinaus geht und eine Philosophie der Produktion miteinbezieht.

Gerade das ist die große mission des Action design. Das Konzept der Bewegung die dem Produkt angeboren ist, ist in gewißem Sinne ein Ausdruck der Bewegung der innersten Identität der Firma Naos. Nicht nur der Gegenstand ist in Bewegung, sondern die gesamte Philosophie der Firma. In einem globalen Markt, der wechselhaft und im Fluß ist, mit Szenarien die immer mehr beschleunigen, ist es notwendig, daß der Fluß der Stimuli und der Vorschläge kontinuierlich ist, daß er variiert aber kohärent ist. Der Fluß ist Bewegung, die Bewegung ist Action Design.

NAOS

VIA O. ROSAI, 1
50063 FIGLINE E INCISA VALDARNO
FIRENZE - ITALY

TEL +39 055 913611

WWW.NAOS.NET
NAOS@NAOS.NET

CREATIVE DIRECTION
PAOLO BONSIGNORE

PHOTOS
RICCARDO CAVALLARI

STILL-LIFE
ALESSANDRO BIANCHI

STYLING
NAYLA ELAMIN

ARTWORK
GUIDO CACIALLI

PRINTED IN ITALY 2024



NAOS
AGAINST FIXED IDEAS